

7 Hints for Precise Current Measurements

CX3300 Series Device Current Waveform
Analyzer (CX3-Class)

Table of Contents

Introduction	3
Current Sensor (CX1101A, CX1102A, CX1103A) Overview	3
Current Sensor Technology	5
Sensor Head Overview	6
Hint #1 – How to Choose the Right Current Sensor	7
Hint #2 – Effective Connection to Your DUT.....	10
Hint #3 – Ground Lead Connection for Accurate Measurements	11
Hint #4 – Understanding Effective Measurement Bandwidth	13
Hint #5 – Influence of the Current Sensor Insertion.....	14
Hint #6 – Applying User Calibration	16
Hint #7 – Low Current Measurement Tips	17
Tune the CX3300 Settings	19



Introduction

The CX3300 series of Device Current Waveform Analyzers, part of the CX3-class of Keysight Device Current Analyzers, can visualize wideband low-level, previously unmeasurable, or undetectable current waveforms. Measuring low-level dynamic current can be challenging due to noise or the bandwidth issues, but the CX3300 solves these issues without compromising noise and bandwidth.

However, in order to take full advantages of the instruments' capabilities, there are some important points to note such as how to select the right current sensor for your application. This application note explains 7 hints that can be undertaken in order to obtain more favorable current measurement with the CX3300.

Current Sensor (CX1101A, CX1102A, CX1103A) Overview

As shown at Figure 1, the CX3300 is configured with a dedicated mainframe and three sensors, CX1101A, CX1102A and CX1103A. These sensors are differentiated by bandwidth, current coverage, and sensitivity, to satisfy various measurement needs.

CX1101A: This sensor is the basic current sensor and covers wide measurement ranges from 40 nA to 1 A and operates under the common mode voltage up to ± 40 V. The maximum bandwidth is 100 MHz (sensor standalone). With the CX1206A dedicated sensor head, the CX1101A can measure up to 10 A.

CX1102A: As with the CX1101A, it covers wide measurement ranges from 40 nA to 1 A, and the maximum bandwidth is 100 MHz (sensor standalone), however the maximum common mode voltage is ± 12 V. This sensor provides dual range, primary and secondary ranges, to support a measurement across a wide dynamic range. Note that the secondary range is fixed as 1/100 of the primary range ¹, and each range occupies the measurement channel respectively.

CX1103A: The CX1103A supports the series' minimum measurable current, and the series' maximum bandwidth. This sensor must be placed at the low side of the DUT (circuit common).

¹ Except for the primary 1A range which operates with the 20 mA secondary range.

CX3300 mainframe

- Max. 200 MHz bandwidth
- Max. 1 GSa/s sampling rate
- Max. 256 Mpts memory depth

Intuitive GUI on wide multi-touch screen enables you analyze and debug the waveform interactively.



Similar look & feel to an oscilloscope enables you to start up quickly.

Sensor connector inputs (2ch or 4ch)

CX1101A Single channel current sensor

- 40 nA to 10 A
- Max. 100 MHz bandwidth
- Max. 40 V common mode voltage

CX1102A Dual channel current sensor

- 40 nA to 1 A
- Max. 100 MHz bandwidth
- Max. 12 V common mode voltage

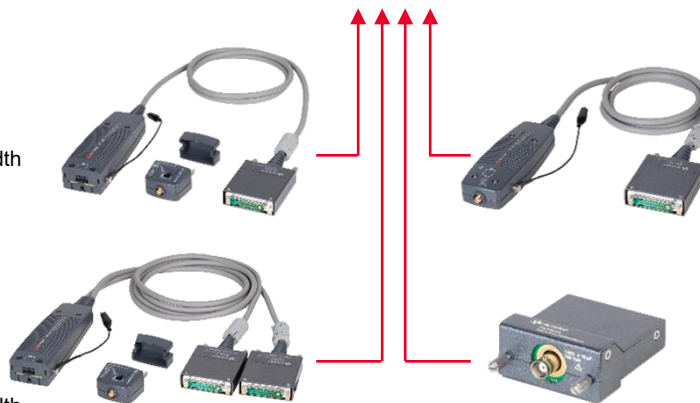

CX1103A Low side current sensor

- 150 pA to 20 mA
- Max. 200 MHz bandwidth
- Max. 1.0 V common mode voltage (with 50 Ω input on)

CX1151A Passive Probe Interface Adapter (for voltage monitor)

- Max. 80 V (with 1/10 probe)

Application examples:

- Maximizing battery life of low power IoT, M2M, wearable chipset, or device development
- Advanced semiconductor or non-volatile memory devices such as ReRAM and PRAM research
- Development and debug of the MCU or ECU efficiently

Figure 1. CX3300 product overview

Current Sensor Technology

There are several methods for measuring the current and they are classified into two groups according to the connection type: contact or non-contact. Generally, a current sensing method with contact has higher sensitivity, and the CX3300's three current sensors employ it. The major conventional contact current sensing method is to measure the voltage between a shunt resistor and calculate the current from the measured voltage and the shunt resistor as shown at Figure 2a. There is a trade-off between the sensitivity and the bandwidth, and the higher sensitivity can be achieved using a larger shunt resistor, while the bandwidth is narrower with a larger shunt resistor.

In contrast, the new technology used in the CX3300's current sensors, as shown at Figure 2b, enables you to maintain very good low current measurement sensitivity across a wide frequency range. The CX3300 mainframe works in tandem with the sensors, and they are both optimized for the measurement of current.

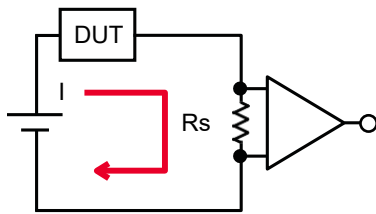

Figure 2a. Conventional current measurement with a shunt resistor

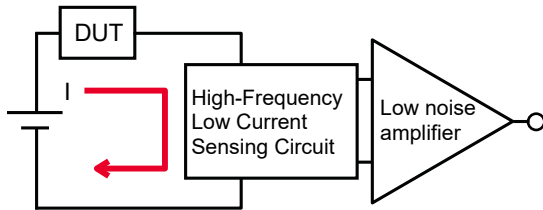







Figure 2b. CX3300's current sensors

Sensor Head Overview

CX1101A and the CX1102A can be used with a variety of different sensor heads to provide a variety of connectivity as shown in Table 1. The coaxial type connection with SMA connector(s) can provide low noise and wide bandwidth performance. For a quick measurement, the sensor head with a pair of test lead connectors (CX1205A) or a twisted pair cable (CX1204A) should be used. The CX1206A, which is the dedicated sensor head for the CX1101A, has an expander box enabling up to 10 A current measurements using a pair of banana cables.

Note that the CX1103A has a fixed sensor head with the SMA connector to provide the best performance in the bandwidth and low current measurement capability.

Table 1. Sensor head selection

Sensor head	Input connector	CX1101A	CX1102A	CX1103A	Max. Current
CX1201A Coaxial Through 	SMA jack	X	X	N/A	1 A
CX1202A Coaxial Through with V monitor 	SMA jack	X	X	N/A	1 A
CX1203A Coaxial termination 	SMA jack (center: +, outer: -)	X	X	N/A	1 A at 0 Ω , 70 mA at 50 Ω
CX1204A Twisted Pair Adapter 	(Shielded twisted pair cables)	X	X	N/A	1 A
CX1205A Test lead adapter 	Mini jack (used with test lead)	X	X	N/A	1 A
CX1206A High current adapter with expander, 10 A 	Banana jack	X	N/A	N/A	10 A

Hint #1 – How to Choose the Right Current Sensor

Step 1: Check the measurement current range and required bandwidth

In order to characterize the dynamic current, the most important thing is understanding the current range and required bandwidth for the measurement.

Three types of current sensor are available for the CX3300A and all current sensors have multiple current ranges and the range can be easily changed on the front panel ¹.

Table 2 below shows the bandwidth of the current range of each current sensor. All current sensors have multiple current ranges.

The current measurement is limited between the upper limit and the noise floor of the range. In general, the noise floor can be roughly estimated 1/1000 of the full scale of the range, approximately 3-digits sensitivity is achievable in a single range, though actual noise floor can be influenced by environmental noise and the measurement conditions. The CX1102A provides dual range, primary and secondary range, and the secondary range is fixed as 1/100 of the primary range ², and approximately 5-digits sensitivity is achieved with both ranges in a single measurement.

Table 2. The bandwidth of each current sensor and range

Current range	Maximum bandwidth (-3 dB)			
	CX1101A	CX1102A		CX1103A
		Primary range	Secondary range	
10 A	3 MHz ³	N/A	N/A	N/A
1 A	100 MHz	100 MHz	N/A	N/A
200 mA	100 MHz	100 MHz	N/A	N/A
20 mA	100 MHz	500 kHz	100 MHz	200 MHz
2 mA	100 MHz	500 kHz	100 MHz	75 MHz
200 µA	25 kHz	N/A	500 kHz	9 MHz
20 µA	25 kHz	N/A	500 kHz	2.5 MHz
2 µA	N/A	N/A	N/A	250 kHz
200 nA	N/A	N/A	N/A	100 kHz

1. At -4 dB

¹ Except for the CX1101A 10 A range

² Except for the primary 1A range which operates with the 20 mA secondary range

³ At -4 dB

Step 2: Where to insert the current sensor

In the case of the power consumption measurement of a chip or a module, the current sensor is placed at the high side of the DUT as shown at Figure 3a.

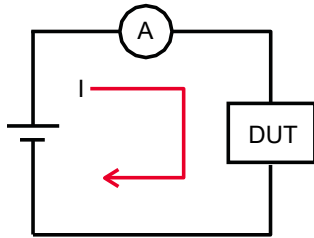

Figure 3a. Measuring at the high side of the DUT (CX1101A or CX1102A)

The CX1101A or the CX1102A can be used for this type of measurement. The common mode voltage can be up to ± 40 V with the CX1101A. The CX1102A supports the wider dynamic range of a single measurement, however the common mode voltage is up to ± 12 V.

When the voltage is not constant at the measurement point such as when measuring the pulsed response of a device, it is recommended that you place the current sensor at the low side (circuit common) of the DUT as shown at Figure 3b. This is because if you are measuring at the high side of the DUT, when the voltage changes, the current sensor measures not only the DUT current but also the charge current to stray capacitance of the cabling and the current sensor. In contrast, while measuring at the low side of the DUT, the current sensor only measures the DUT current, as shown at Figure 4.

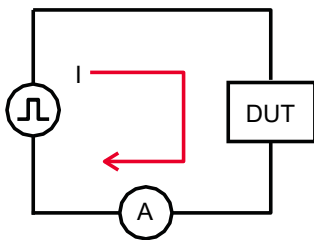
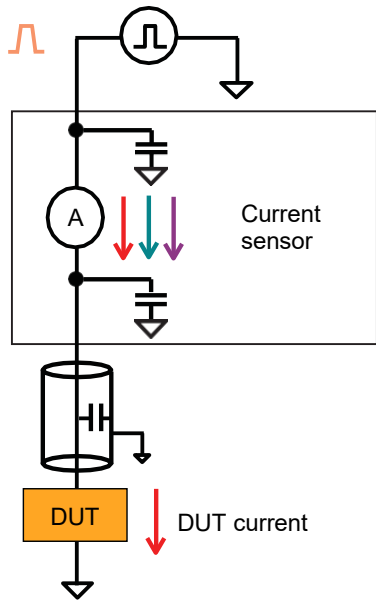

Figure 3b. Measuring at the low side of the DUT (CX1101A, CX1102A, or CX1103A)

All current sensors are used for this case. If the maximum current is under 20 mA, the best sensor to use is the CX1103A, because this sensor supports the widest bandwidth and lowest current measurement capability.

Measuring the pulsed response current at the **high** side of the DUT



Measuring the pulsed response current at the **low** side of the DUT

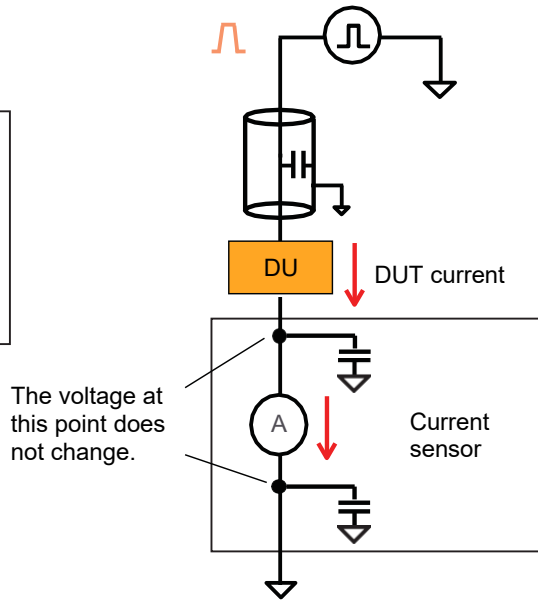

Figure 4. The difference in the pulsed response current measurement at the high side or low side of the DUT

Hint #2 – Effective Connection to Your DUT

How to connect to your DUT?

There are three types of connection supported by the CX1101A and CX1102A, the coaxial (SMA) type, the twisted pair type, and the test lead type. In order to achieve the wider bandwidth, the coaxial (SMA) connection is better. It allows typically up to 100 MHz bandwidth for current measurements. Although the test lead is the easiest type of connection, the measurement bandwidth is limited to 10 MHz or below. The connection type can be specified or sometimes restricted by the DUT, however, it is important to understand that the maximum bandwidth is impacted by the connection type.

Table 3. Sensor head, connection type and maximum bandwidth

Applicable current sensors: CX1101A, CX1102A

Sensor head	Connection type	Max. standalone bandwidth [MHz]
CX1201A Coaxial Through	Coaxial (SMA)	≤ 100
CX1202A Coaxial Through with V monitor		
CX1203A Coaxial termination		
CX1204A Twisted pair adapter	Twisted pair	≤ 10
CX1205A Test lead adapter	Test lead	≤ 10
CX1206A High current adapter with expander, 10 A	Banana plug	≤ 3

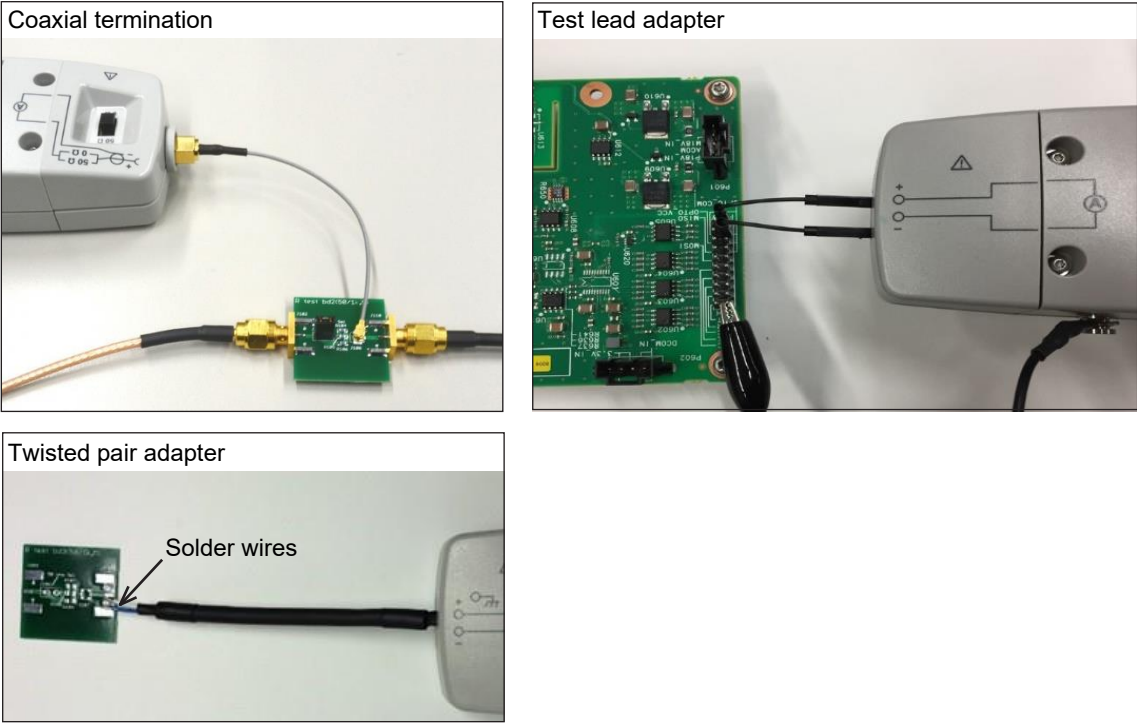

Figure 5. Connection of the sensor head

Hint #3 – Ground Lead Connection for Accurate Measurements

Why a ground lead is necessary?

A ground lead is used for connecting the chassis ground of the current sensor to the circuit common of the DUT. The ground lead connection is required from a safety and low current measurement accuracy viewpoint. In addition, without the connection, the common mode voltage is not guaranteed to be within the specified common mode range of the sensor's input amplifiers. If the voltage of (+) or (-) terminal exceeds the maximum common mode voltage of the current sensor, the current sensor does not work, as shown at Figure 6.

Connecting ground leads is sometimes critical for battery powered devices because the DUT may not be grounded.

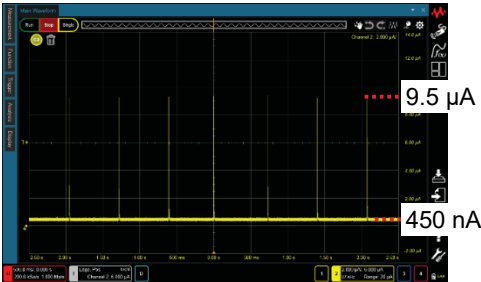

With ground lead

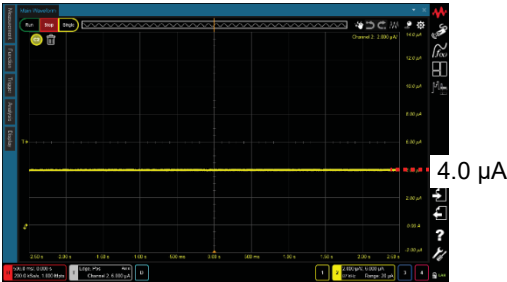

Without ground lead
(No switching waveform is observed)

Figure 6. A switching current waveform of a DC-DC converter with or without the ground lead

Where to connect the ground lead?

Figure 7 below shows where to connect the ground lead. Please note that when measuring the current at the low side of the DUT, connect the ground lead to the negative electrode of the battery, not to the GND terminal of the DUT.

When connecting the current sensor to DUT, connect the ground lead first, then connect the (+) or (-) terminal of the current sensor. When disconnecting the current sensor from DUT, disconnect the current sensor in the reverse order.

Ground lead connection when measuring at the **high** side of the DUT

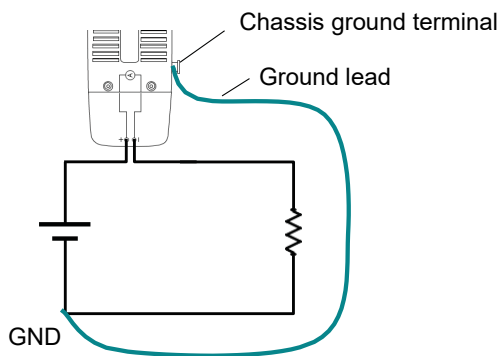

Ground lead connection when measuring at the **low** side of the DUT

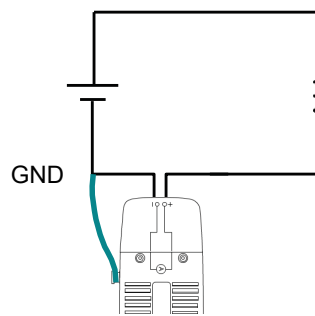

Figure 7. Ground lead connection

Hint #4 – Understanding Effective Measurement Bandwidth

Overview

The maximum effective bandwidth of the instrument is decided by the bandwidth of the mainframe and the current range. In addition, the settings on CX3300, the connection type, and the DUT can limit the actual measurement bandwidth. This hint describes how to estimate the actual measurement bandwidth.

Effective measurement bandwidth of the instrument

- The mainframe has three maximum bandwidth options, 50 MHz, 100 MHz, and 200 MHz.
- The current sensor's bandwidth depends on the current sensor and the range and if you change the range, the bandwidth is changed automatically.

The effective bandwidth when a current sensor is connected to a mainframe can be estimated by the equation shown below.

$$BW_{effective} = \frac{1}{\sqrt{\left(\frac{1}{BW_{sensor}}\right)^2 + \left(\frac{1}{BW_{mainframe}}\right)^2}}$$

As an example, Table 4 shows the maximum effective bandwidth for each of the three sensors when combined with a 200 MHz bandwidth mainframe.

Table 4. Maximum effective bandwidth

Sensor max. bandwidth (-3 dB)	Mainframe max. bandwidth (-3 dB)	Max. effective bandwidth (-3 dB)
CX1101A	100 MHz	90 MHz
CX1102A	200 MHz	90 MHz
CX1103A	200 MHz	140 MHz

Settings on the CX3300

In addition to the mainframe options and current range, the sampling rate and bandwidth limit settings change the actual effective bandwidth. You can check the effective bandwidth of the instrument as calculated by the mainframe option, current range, sampling rate and bandwidth limit settings in each channel's mini dialog box on the front panel as shown at Figure 8.



Figure 8. Calculated effective bandwidth of the instrument

Connection type

As discussed in Hint #2, if you want to maximize the measurement bandwidth, it is recommended that you use the coaxial connection with the sensor head that has the SMA connector.

DUT

For supply current measurement, the measurement bandwidth can be narrowed by the decoupling capacitance on the DUT and the input resistance of the current sensor, as shown at Figure 9.

The input resistance of current sensor depends on the current sensor and range and in the case of the CX1101A, it is 410 mΩ or 50 Ω. For example, with a decoupling capacitor, 0.1 μF, with the range which has 410 mΩ input resistance, the measured bandwidth is approximately 3.9 MHz, while with the range of 50 Ω, it degraded to be 31 kHz. In order to minimize the influence, use the upper range which has the smaller input resistance, or remove or minimize the decoupling capacitance.

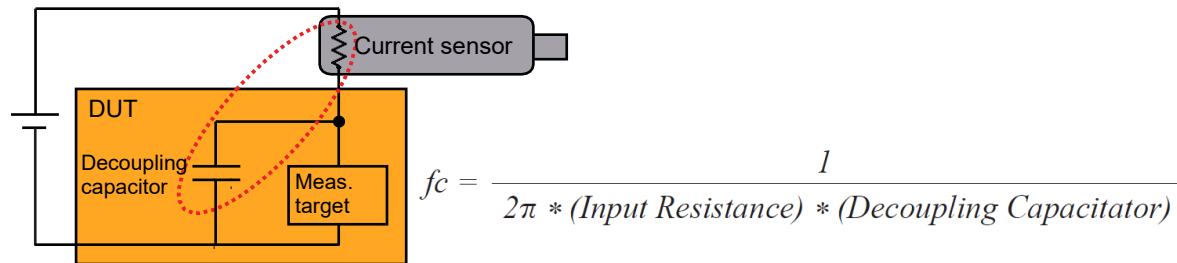

Figure 9. Block diagram of input resistance of current sensor and decoupling capacitance on DUT

Hint #5 – Influence of the Current Sensor Insertion

Overview

The CX3300's three current sensors employ the current sensing method with contact to achieve the wide bandwidth, sensitivity and low noise. However, the influence of the current sensor insertion cannot be zero, though the current sensors are designed to minimize the loading effect. This Hint describes the influence of current sensor insertion.

The voltage drop due to the input resistance of the current sensor

The major influence of the current sensor insertion is the voltage drop due to the input resistance of the current sensor. The input resistance depends on the current sensor and the range, as shown in Table 5. When you switch the range, it is also changed automatically.

If the current is not large, the voltage drop may be negligible. However, if the current is large and the voltage drop is not negligible, use the upper range which has the smaller input resistance in order to minimize the influence.

Table 5. Input resistance of the current sensor and range

CX1101A

Range	Typical input resistance
10 A	15 mΩ
1 A	
200 mA	410 mΩ
20 mA	
2 mA	
200 μA	50 Ω

CX1102A

Range		Typical input resistance
Primary	Secondary	
1 A	20 mA	410 mΩ
200 mA	2 mA	
20 mA	200 μA	50 Ω
2 mA	20 μA	

CX1103

Range	Typical input resistance
20 mA	
2 mA	50 Ω
200 μA	(50 Ω input ON)
20 μA	
2 μA	4 Ω
200 nA	(50 Ω input OFF)

The narrowed bandwidth by the input resistance and the decoupling capacitance on the DUT

As discussed in Hint #4, the input resistance can narrow the measurement bandwidth with the decoupling capacitance on the DUT. In order to minimize the influence, use the upper range which has the smaller input resistance, or remove or minimize the decoupling capacitance.

Other information to estimate the influence of the current sensor insertion

Figure 10 shows the load model of the CX1101A with the CX1203A sensor head. You can estimate the influence of the current sensor insertion by applying the model on a simulation software. The [User's guide for CX1100 Series Accessories for CX3300](#) has load models of other sensor and sensor heads, please refer to the User's Guide if needed.

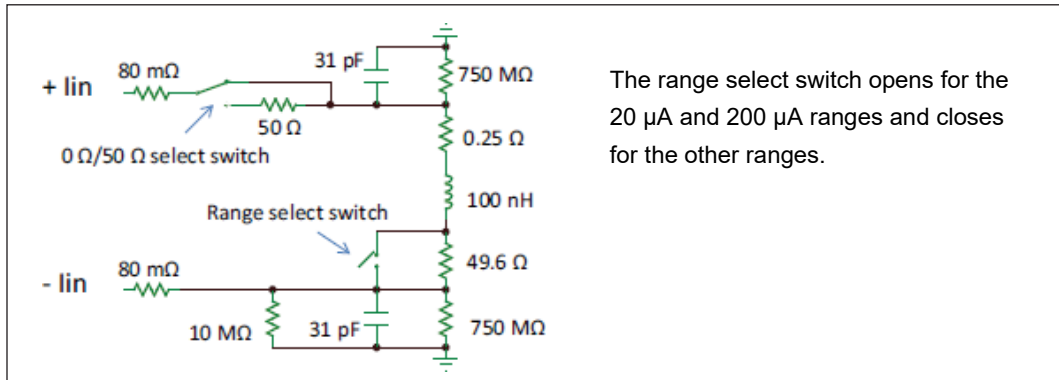

Figure 10. Load model of CX1101A with CX1203A (Modeled at 1 MHz)

Hint #6 – Applying User Calibration

Overview

The CX3300 provides the user calibration capability for making more accurate measurements. It is not mandatory for the operation, but very effective if you achieve better DC accuracy. For example, the offset current of the CX1101A 20 mA range is $\pm 2.9\%$ of the range and it will be $\pm 0.3\%$ in 24 hours after performing the User Calibration.

How to perform User Calibration

1. Connect the current sensors to the CX3300. After the connection, warm up them for 30 minutes.
2. Connect the Aux Out and the current sensor to the furnished cable and adapter. Figure 11 below shows the connection diagram for the User Calibration.
3. Press the Menu key several times to open the Configuration dialog box. Then click User Calibration to display the Configuration \rightarrow User Calibration screen. Follow the procedure on the User Calibration window.

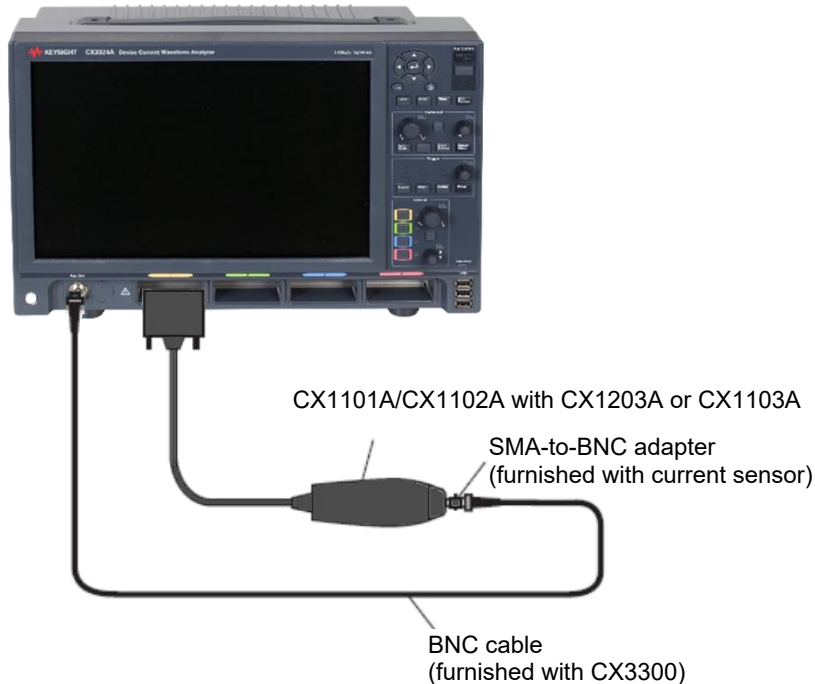

Figure 11. Connection diagram for the User Calibration

Hint #7 – Low Current Measurement Tips

Overview

The CX3300 has the capability to visualize wideband, low-level current waveforms. However, in order to achieve the low current measurement in an actual measurement environment, we need to minimize the influence of unexpected noise, minimize the offset current and tune the CX3300 settings.

Minimize the influence of unexpected noise

The following is an effective method of reducing unexpected noise.

- Use an electrostatic shield
The electrostatic shield is effective to reduce the influence of external noise. The shield should be connected to the chassis ground terminal of the current sensor. Figure 12 shows a connection example with two ground leads. Figure 13 is the actual measurement example with or without a shield.
- Avoid any mechanical vibration or shocks which can induce the current on MLCC (Multilayer Ceramic Capacitor).
- Use as short a coaxial or twisted pair cable as possible. The long single core cable can be easily influenced by external noise.

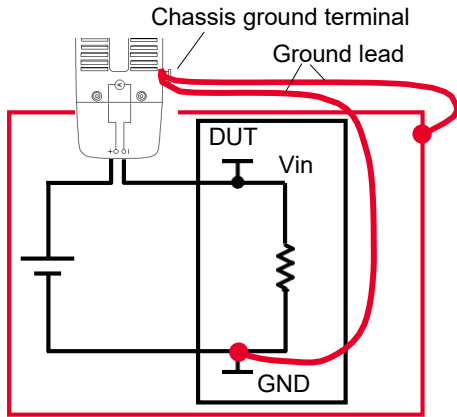

Figure 12. Connection diagram of electrostatic shield

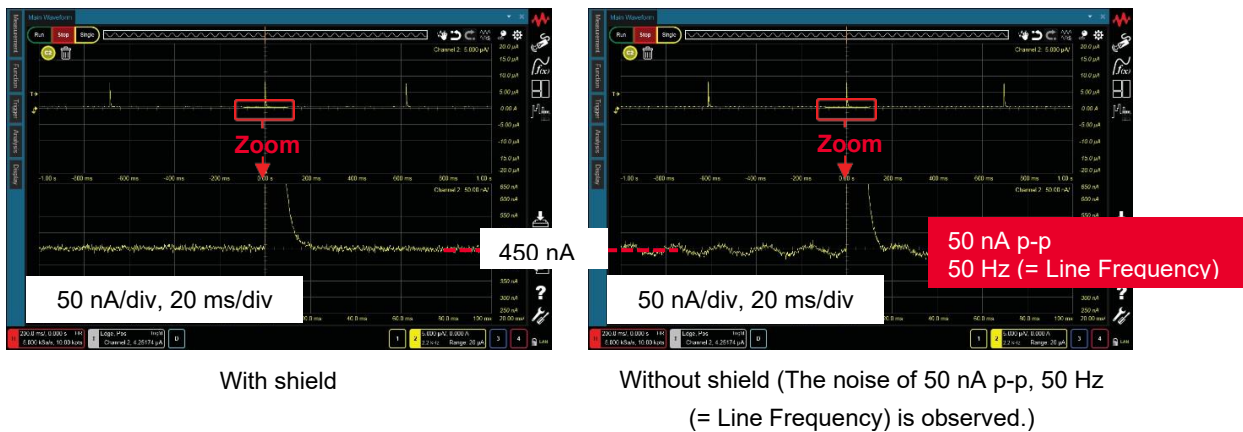

Figure 13. A switching current waveform of a DC-DC converter with or without electrostatic shield

Minimize the offset current

As described in Hint #6, the offset current of the current sensor itself can be minimized by performing the User Calibration. Furthermore, in order to minimize the offset current with the DUT, just before the actual measurement, measure the offset current and subtract the offset current from the actual measurement current. The Subtract function should be convenient for this.

Note the following points for offset current measurement connections:

- Connect either of the (+) or (-) terminal of current sensors to the stable voltage on the DUT.
- Connect the ground lead to the circuit common of the DUT.
- Make a connection not to flow into the current sensor.

Figure 14 shows a connection example at offset current measurement with the CX1205A sensor head and test lead.

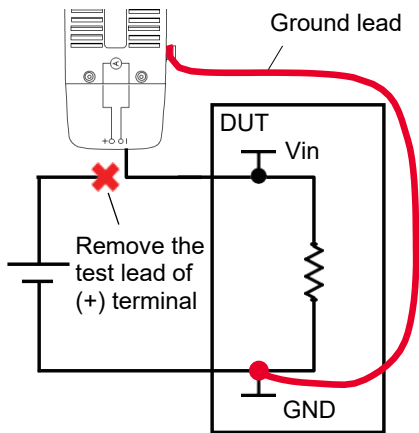

Figure 14. Connection example at offset current measurement

Tune the CX3300 Settings

Use a lower current range

Set the minimum current range which is enough to cover the peak current of your DUT if the input resistance and the bandwidth of the range is acceptable, because the lower current range has lower noise and lower offset capabilities.

Use a high-resolution mode

The CX3300 has two resolution modes, 14-bit (high speed mode) or 16-bit (high resolution mode), and the mode can be changed by pressing the “High Reso” button on the front panel. The high-resolution mode has the lower noise floor especially in the lower bandwidth and can obtain the clearer waveform. Table 6 below shows the differences between the two modes.

Table 6. The differences between the high speed and high-resolution modes

Resolution	Max. sampling	Max. bandwidth
14-bit (high speed mode)	1 GSa/s	200 MHz
16-bit (high resolution mode)	75 MSa/s	15 MHz

Set the bandwidth limit wide enough for the measurement

There is a trade-off between the bandwidth and noise floor, the lower noise floor with lower bandwidth. Set the bandwidth limit wide enough for the measurement to achieve a better noise floor.

Set a sampling rate that is low enough to observe the waveform with 'Normal' acquisition mode

The CX3300 remains at 1 GSa/s internally and shows the averaged value at the specified sampling interval with 'Normal' acquisition mode. It means you can observe the average waveform and reduce the measurement data points at the same time.

Apply a filter function

The CX3300 has several post-filter functions such as Smooth, Low Pass and High Pass. The post-filter function does not change the original waveform, you can compare the original and the filtered waveform.

Apply averaging

The averaging function is effective when the measurement target is the repetitive waveform. You can keep the bandwidth and sampling rate with a single measurement but can reduce the noise floor by averaging the same timing data.