



Flame Miniature Spectrometer User Manual



For Products: FLAME-S, FLAME-T
Document: 225-00000-000-11-201503b

A HALMA COMPANY

AMERICAS & WORLD HEADQUARTERS

Phone: +1 727-733-2447

Fax: +1 727-733-3962

Sales: info@oceanoptics.com

Orders: orders@oceanoptics.com

Support: techsupport@oceanoptics.com

Ocean Optics, Inc.

830 Douglas Ave.
Dunedin, FL 34698
USA

Manufacturing & Logistics

4301 Metric Dr.
Winter Park, FL 32792
USA

EUROPE, MIDDLE EAST & AFRICA

Phone: +31 26-319-0500

Fax: +31 26-319-0505

Email: info@oceanoptics.eu

Germany : +49 711-341696-0

UK : +44 1865-811118

France : +33 442-386-588

Sales & Support

Geograaf 24
6921 EW Duiven
The Netherlands

Manufacturing & Logistics

Maybachstrasse 11
73760 Ostfildern
Germany

ASIA

Phone: +86 21-6295-6600

Fax: +86 21-6295-6708

Email: asiasales@oceanoptics.com

Japan & Korea: +82 10-8514-3797

Ocean Optics Asia

666 Gubei Road
Kirin Tower Suite 601B
Changning District
Shanghai
PRC, 200336

www.oceanoptics.com

Copyright © 2015 Ocean Optics, Inc.

All rights reserved. No part of this publication may be reproduced, stored in a retrieval system, or transmitted, by any means, electronic, mechanical, photocopying, recording, or otherwise, without written permission from Ocean Optics, Inc.

Trademarks

All products and services herein are the trademarks, service marks, registered trademarks or registered service marks of their respective owners.

Limit of Liability

Every effort has been made to make this manual as complete and as accurate as possible, but no warranty or fitness is implied. The information provided is on an "as is" basis. Ocean Optics, Inc. shall have neither liability nor responsibility to any person or entity with respect to any loss or damages arising from the information contained in this manual.

Table of Contents

About This Manual.....	v
Document Purpose and Intended Audience.....	v
Document Summary.....	v
Product-Related Documentation.....	vi
Document Version.....	vi
Patent Pending Notice.....	vi
Warranty.....	vi
ISO Certification.....	vii
Chapter 1: Introduction.....	1
Product Introduction.....	1
Product Features.....	2
Typical Applications.....	3
Product Versions.....	6
Chapter 2: Installation and Setup.....	9
What's In the Box.....	9
Flame Installation.....	9
Software Installation.....	10
About OceanView.....	11
Hardware Setup.....	11
Hardware Features.....	13
Flame LEDs.....	13
Change the Slit.....	13
Accessories.....	14
Cables and Connectors.....	14
DB15 Connector Cable (FLAME-CBL-DD4P-DB15P).....	15
PAK50 Connector Cable (FLAME-CBL-DD4P-PAK50P).....	16
Breakout Box (HR4-BREAKOUT).....	16
Interchangeable Slits.....	16
Light Sources, Cuvette Holders and Other Accessories.....	17
Measurement Techniques – Typical Set-ups.....	17
Absorbance.....	17
Common UV-Vis Applications.....	18

Reflectance and Transmission	18
Common UV-Vis Reflectance Applications	18
Common UV-Vis Transmission Applications	18
Fluorescence	19
Common Fluorescence Applications	19
Irradiance	20
Common Irradiance Applications	21
Chapter 3: Flame Operation with OceanView	23
Overview	23
Launch OceanView	23
OceanView Main Screen	24
Connect the Flame in OceanView	25
Set Acquisition Parameters	25
Quick View and Device Response	26
Continuous and Single Acquisitions	26
Projects and Methods	28
Spectroscopy Application Wizards	28
Dark and Reference Measurements	29
Schematic View	29
Chapter 4: Troubleshooting	31
Overview	31
Microsoft Windows Operating Systems	32
Apple Mac Operating Systems	33
Linux Operating Systems	33
Chapter 5: How the Flame Spectrometer Works	37
Overview	37
Chapter 6: Technical Specifications	45
Mechanical Diagram	48
Electrical Pinout	49
DD4 Accessory Connector Pinout Diagram	49
SPI	51
I2C	52
CCD Overview	52
CCD Detector	52
CCD Well Depth	52

Signal Averaging	53
Internal Operation	54
Pixel Definition	54
CCD Detector Reset Operation	54
Timing Signals	55
Strobe Signals	55
Single Strobe	55
Continuous Strobe	55
Synchronizing Strobe Events	55
External Triggering	56
Triggering Modes	56
Normal	56
External Synchronous Trigger Mode	56
External Hardware Level Trigger Mode	57
External Hardware Edge Trigger Mode	57
Chapter 7: Calibration	59
Overview	59
Wavelength Calibration	59
About Wavelength Calibration	59
Calibrating the Spectrometer Wavelength	60
Preparing for Calibration	60
Calibrating the Wavelength of the Spectrometer	60
Irradiance Calibrations	63
Chapter 8: Firmware and Advanced Communications	65
FLAME-S Firmware	65
Hardware Description	65
USB Information	65
Instruction Set	65
Command Syntax	65
USB Command Summary	66
USB Command Descriptions	67
Flame –S Serial Port Interface Communications and Control Information	81
Hardware Description	81
Instruction Set	81
Command Descriptions	83
FLAME-T Firmware	91
Hardware Description	91
Spectral Memory Storage	91
Instruction Set	91
Command Syntax	91

Table of Contents

USB Command Summary	92
USB Command Descriptions	92
Flame –T Serial Port Interface Communications and Control Information.....	105
Hardware Description.....	105
Spectral Memory Storage	105
Instruction Set	105
Command Summary	106
Command Descriptions.....	107
Examples	115
Index	117

About This Manual

Document Purpose and Intended Audience

Thank you for choosing Ocean Optics! We hope that you'll be delighted with your decision. This document provides the users of Flame Spectrometers with instructions for setting up, calibrating and performing experiments with their spectrometer. It also contains detailed technical specifications and information about firmware and hardware integration. If you can't find what you're looking for in this document, please do not hesitate to contact us at techsupport@oceanoptics.com or via www.oceanoptics.com.

Document Summary

Chapter	Description
Chapter 1: Introduction	Introduces the product features. Contains descriptive information about the Flame Spectrometer. It also provides a list of system requirements, typical applications, and product versions.
Chapter 2: Installation and Setup	Provides installation instructions, including how to set up the Flame with OceanView. Also includes package contents and typical set-ups for different measurement techniques.
Chapter 3: Flame Operation with OceanView	Describes how to use the Flame with OceanView software, including how to connect, acquire, save and other basic features.
Chapter 4: Troubleshooting	Contains recommended steps to isolate and correct common problems.
Chapter 5: How the Flame Spectrometer Works	Describes how the Flame operates, illustrating the various parts and functions.
Chapter 6: Technical Specifications	Contains technical specifications and connector pinouts for the Flame Spectrometer.
Chapter 7: Calibration	Provides instructions for calibrating the Flame Spectrometer.
Chapter 8: Firmware and Advanced Communications	Contains a description of firmware commands.

Product-Related Documentation

You can access documentation for Ocean Optics products by visiting our website at <http://www.oceanoptics.com>. Select *Technical Operating Instructions*, then choose the appropriate document from the available drop-down lists.

Document for...	Document Location
OceanView software	http://oceanoptics.com/wp-content/uploads/OceanViewIO.pdf
SpectraSuite software	http://oceanoptics.com/wp-content/uploads/SpectraSuite.pdf
HR-4 Breakout Box	http://oceanoptics.com/wp-content/uploads/HR-4-Breakout-Box.pdf
External triggering	http://oceanoptics.com/wp-content/uploads/External-Triggering-Options_Firmware3.0andAbove.pdf
Replacing the slit	http://oceanoptics.com/wp-content/uploads/INTSMA-Slit.pdf
Device driver issues	http://oceanoptics.com/wp-content/uploads/Correcting-Device-Driver-Issues.pdf

Ocean Optics offers a Glossary of spectroscopy terms to help you further understand your state-of-the-art products and how they function, located at:

<http://oceanoptics.com/glossary/>.

Document Version

Document Number	Version
225-00000-000-11-201503	First release
225-00000-000-11-201503b	Updates technical specifications, troubleshooting instructions, and other minor issues.

Patent Pending Notice

The Flame spectrometer is covered by Patents Pending. Any violation of Ocean Optics intellectual property will be prosecuted.

Warranty

Our 3-Year Warranty covers Ocean Optics miniature fiber optic spectrometers, light sources and sampling accessories – regardless of the application – from manufacturing defects. It also covers fibers and probes for a full 12 months: <http://oceanoptics.com/services/exclusive-3-year-warranty/>.

This comprehensive warranty ensures you of the highest level of craftsmanship and reliability for years to come. No other manufacturer offers such a solid guarantee of quality and reliability. The Ocean Optics 3-Year Warranty applies to Ocean Optics equipment (excluding OEM configurations) purchased on or after July 1, 2010. The warranty covers parts and labor needed to repair manufacturing defects that occur during the warranty period. We also will cover the costs of shipping warranty-related repairs from our customers to Ocean Optics and from us to our customers.

ISO Certification

Ocean Optics, the industry leader in miniature photonics, has been certified for ISO 9001:2008 certification applicable to the design and manufacture of electro-optical equipment since 2009.

Compliance

 **WARNING**

This is a Class A product. In a domestic environment this product may cause radio interference in which case the user may be required to take adequate measures.

FCC COMPLIANCE

This equipment has been tested and found to comply with the limits for a Class A digital device, pursuant to Part 15 of the FCC Rules. These limits are designed to provide reasonable protection against harmful interference when the equipment is operated in a commercial environment. This equipment generates uses and can radiate radio frequency energy and, if not installed and used in accordance with the instruction manual, may cause harmful interference to radio communications. Operation of this equipment in a residential area is likely to cause harmful interference in which the user will be required to correct the interference at his own expense.

 **WARNING:** The authority to operate this equipment is conditioned by the requirement that no modifications will be made to the equipment unless the changes or modifications are expressly approved by the manufacturer.

Chapter 1

Introduction

Product Introduction

The Flame Spectrometer is the latest generation of Ocean Optics' ubiquitous Czerny-Turner design. With the release of the world's first miniature spectrometer in 1993, Ocean Optics helped to make spectroscopy portable, inexpensive and flexible in a way that was never before possible. Researchers, educators and OEM manufacturers embraced the technology and have used it in ways we never thought possible.



Flame Spectrometer

Now, fueled by our passion for solving problems, and inspired by the feedback of our customers we have reinvented our core miniature spectrometer platform to meet the most demanding challenges of today's applications. Flame combines our heritage, creativity and insight in a way that delivers the power of miniature, modular spectroscopy without compromise.

Flame is built using industry leading manufacturing techniques that help deliver high thermal stability and low unit to unit variation without compromising the flexibility and configurability that are the hallmark of the design. New features such as interchangeable slits, indicator LEDs and simpler device connectors deliver more freedom and less frustration.

Whether you are an educator looking for an instrument to teach students the basic principles of spectroscopy, a research lab looking to make a breakthrough, a scientist working in the field to study the world around us or an engineer working to integrate a spectrometer into an OEM system, the Flame will provide you with the performance and features you need to make your UV-Vis spectroscopy application successful.

Product Features

- Incredibly configurable, with over 1 billion possible off-the-shelf configurations across the wavelength range 190-1100nm. Balanced throughput, resolution and range to optimize the spectrometer for your application.
- Works seamlessly with Ocean Optics' large range of light sources, accessories and software
- Easy to use. Plug and play via the micro-USB connection.
- User-interchangeable slit allows you to vary the resolution and throughput of the spectrometer on demand. In seconds, go from high resolution to high throughput using the same spectrometer.
- Indicator LEDs show the power and data transfer status of the spectrometer at all times.
- Compact and lightweight. The "go anywhere" spectrometer for the lab and in the field.
- The introduction of new, high-tech manufacturing methods has dramatically improved optical alignment accuracy resulting in improved unit-to-unit performance and reproducibility.
- High thermal stability allows for accurate and repeatable measurements in demanding environments.
- Choice of USB or RS-232 serial communications supported by drivers and software that make it easy to integrate into almost any system.
- 8 GPIO pins and the ability to provide power to external devices through the 40-pin connector.

Key Feature	Best For...	Example Applications
User-Interchangeable Slits	Users who wish to vary resolution and throughput during measurements, or switch from absorbance to fluorescence in minutes	Life science and other labs using a wide variety of biological samples
Indicator LEDs	Convenient visual reference for spectrometer operation and status	Teaching and general lab use
Thermal Stability	Applications that require repeatable results in industrial and other environments with varying temperatures and conditions	LED binning and light metrology, process monitoring
Reduced Unit to Unit Variation	OEM applications such as uncalibrated sensitivity and other measurement needs where users benefit from low variance	OEM manufacturers of analytical instrumentation

Key Feature	Best For...	Example Applications
Configurability	Optimizing your spectrometer for application-specific requirements; adjusting range, throughput and resolution and adding features such as filters as required	Laser characterization, low signal fluorescence and optimizing for specific absorbance bands
Plug & Play Operation	Users that want the convenience of simple, fast operation via the micro USB connection; lets users take the measurement to the sample	Remote sensing measurements in the field, including air and water quality monitoring and solar irradiance
Ease of Integration	OEMs and developers who need to integrate a spectrometer as part of a system via USB or RS-232	Engineering labs, developers, OEM manufacturers; works with LabVIEW and other design platforms

Typical Applications

Application Area	Examples
Light Laser LED	Laser Characterization
	LED Measurement
	Light Metrology Measurement
Research and Education	Applied Research
	Basic Research
	Teaching Labs for Physics, Chemistry, Biomed
Life Sciences	Biotechnology
	Medical Diagnostics
	Protein and Nucleic Acid Analysis
Materials Identification	Biomaterial Analysis
	Metallurgical Analysis
	Polymer Analysis
	Semiconductor Materials Analysis
Semiconductors Processing and Thin Film	Plasma Monitoring

1: Introduction

Application Area	Examples
Metrology	Process Endpoint Detection
	Thickness Measurement
Farm to Table Technologies	Agricultural Measurements and Monitoring
	Food and Beverage Quality Control
	Food Safety
Energy Technologies	Biofuels Analysis
	Mining and Exploration
	Oil and Petroleum Analysis
	Photovoltaic Analysis
	Solar Simulators
Anti-Counterfeit	Testing and Qualification
	Product Identification and Authentication
Quality Control and Process Monitoring	Defect Identification
	Raw Material Inspection
	Verification Testing
Environmental Monitoring	Air and Water Quality Analysis
	Remote Sensing
	Volcanic Research

You can find more information about applications of UV-Vis spectroscopy and the Flame at www.oceanoptics.com.

Specifications Summary

Specification	FLAME-S	FLAME-T
SPECTROSCOPIC		
Optical resolution	~0.1-10.0 nm FWHM (configuration dependent)	
Signal-to-noise ratio	250:1	300:1
Integration time	1 ms – 65 seconds	3.8 ms – 10 seconds
Stray light	<0.05% at 600 nm; <0.10% at 435 nm	
Corrected linearity	>99.8%	
ELECTRONIC		
A/D resolution	16 bit	
Power requirement (spectrometer functions)	250 mA @ +5 VDC	
Inputs/Outputs	8 x digital user programmable GPIOs	
Trigger modes	4 modes	
Strobe functions	Yes	
Gated delay feature	Yes	
Connectors	Micro-USB and JAE DD4 40-pin connector	
DETECTOR		
Detector	Sony ILX511B linear silicon CCD array	Toshiba TCD1304AP linear CCD array
Detector range	190-1100 nm	
Pixels	2048 pixels	3648 pixels
PHYSICAL		
Dimensions	88.9 mm x 63.5 mm x 31.9	
Weight	265 g	

Product Versions

Many variants of the Flame Spectrometer exist. Ocean Optics offers both preconfigured units as well as custom-configured units, enabling you to order a customized spectrometer optimized for your application. You can tell which kind of spectrometer you have by looking at the product code, located on the bottom of your spectrometer.

You can find more information about the various components and possible configuration options in Chapter 5: [How the Flame Spectrometer Works](#).

Product Code Taxonomy

Spectrometer Family?	Detector Type?	Preconfigured or Custom?
FLAME-	S- (Sony ILX511B)	UV-VIS, VIS-NIR, XR
		CUSTOM
	T- (Toshiba TCD1304AP)	UV-VIS, VIS-NIR, XR
		CUSTOM

Preconfigured Models

FLAME-S Preconfigured Models (Sony ILX511B Detector)								
	Model	Range (nm)	Std Slit (μm)	Resolution std slit (nm)	Grating #	Mirror Type	Filters & Detector Options*	Lens
General Purpose	FLAME-S-UV-VIS	200-850	25	~1.5	1	Al	OSF 200-850	no
	FLAME-S-UV-VIS-ES							L2
	FLAME-S-VIS-NIR	350-1000	25	~1.5	3	Al	OSF 350-1000	no
	FLAME-S-VIS-NIR-ES							L2
Extended Range	FLAME-S-XR1	200-1025	25	~2	31	Al	OSF 200-1100	no
	FLAME-S-XR1-ES							L2
Irradiance	FLAME-S-RAD	360-1000	50	~3	2	Al	UV Window	no

FLAME-T Preconfigured Models (Toshiba TCD1304TP Detector)								
	Model	Range (nm)	Std Slit (μm)	Resolution std slit (nm)	Grating #	Mirror Type	Filters & Detector Options*	Lens
General Purpose	FLAME-T-UV-VIS	200-850	25	~1.5	1	Al	OSF 200-850	no
	FLAME-T-UV-VIS-ES							L2
	FLAME-T-VIS-NIR	350-1000	25	~1.5	3	Al	OSF 350-1000	no
	FLAME-T-VIS-NIR-ES							L2
Extended Range	FLAME-T-XR1	200-1025	25	~2	31	Al	OSF 200-1100	no
	FLAME-T-XR1-ES							L2
Irradiance	FLAME-T-RAD	360-1000	50	~3	2	Al	UV Window	no

For more information and specifications on preconfigured models, see www.oceanoptics.com.

Installation and Setup

What's In the Box

- ❑ **Packing List**

The packing list is inside a plastic bag attached to the outside of the shipment box (the invoice arrives separately). It lists all items in the order, including customized components in the spectrometer (such as the grating, detector collection lens, and slit). The packing list also includes the shipping and billing addresses, as well as any items on back order.

- ❑ **Flame Spectrometer**

Your Flame spectrometer arrives pre-calibrated and ready to plug and play.

- ❑ **Micro USB Cable**

Use this cable (CBL-MICROTOA-USB) to connect your spectrometer to a computer running on a Windows, Mac or Linux operating system.

- ❑ **Wavelength Calibration Data Sheet**

Each spectrometer is shipped with a Wavelength Calibration Data Sheet that contains information unique to your spectrometer. OceanView reads this calibration data from your spectrometer when it interfaces to a computer via the USB port.

Note

Please save the Wavelength Calibration Data Sheet for future reference.

Flame Installation

The following procedure provides general instructions for getting your new Flame spectrometer up and running.

Caution

Be sure to install the software BEFORE connecting the spectrometer to your PC. The software installs the drivers required for spectrometer installation. If you do not install the software first, the system will not properly recognize the spectrometer.

If you have already connected the Flame to a computer running on a Windows platform prior to installing the operating software, consult Chapter 4: [Troubleshooting](#) for information on correcting a corrupt Flame installation.

► Procedure

Use the following procedure to get your system up and running quickly. See [Hardware Setup](#) for more detailed information.

1. Install your spectroscopy operating software by following the installation wizard prompts. See [Software Installation](#) for more in-depth information.
2. Locate the micro USB cable provided with the spectrometer. Connect the spectrometer to the USB port on your computer using this cable.

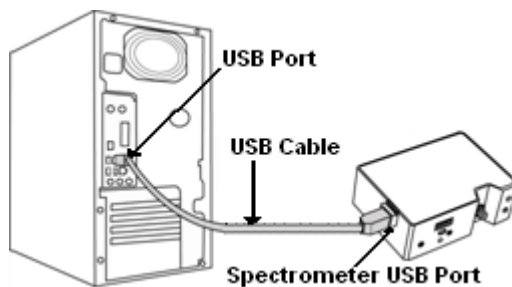

3. Take measurements. Refer to your spectrometer operating software manual for information on the software user interface.

Software Installation

Use OceanView version 1.5 and above for Flame. Flame can be used with SpectraSuite, but will appear as a USB2000+ Spectrometer in the software. You can use OceanView or SpectraSuite on the following operating systems.

Caution

Be sure that you download the correct software package for your computer version (32 or 64-bit). See the Frequently Asked Questions in Chapter 4: [Troubleshooting](#) for more information on determining your computer version.

Software OS	Windows						Apple	Linux
	2000	XP	Vista	7	8	8.1		
OceanView		√	√	√	√	√	OS X Version 10.5 or later on Intel processor	Any version released for an x86 or amd64 platform since 2010
SpectraSuite	√	√	√	√			OS X Version 10.0 or later	Red Hat 9 or later, Fedora (any version), Debian 3.1 or later (Sarge), SUSE (9.0 or later), Centos (any version), and Ubuntu

About OceanView

OceanView is the latest generation of operating software for all Ocean Optics spectrometers. It is a Java-based spectroscopy software platform that operates on Windows, Macintosh and Linux operating systems. The software can control any Ocean Optics USB spectrometer and device.

OceanView is a user-customizable, advanced acquisition and display program that provides a real-time interface to a variety of signal-processing functions. With OceanView, you have the ability to perform spectroscopic measurements (such as absorbance, reflectance, and emission), control all system parameters, collect and display data in real time, and perform reference monitoring and time acquisition experiments. Consult the OceanView manual for hardware requirements when using OceanView (see [Product-Related Documentation](#)).

Hardware Setup

The Flame Spectrometer connects to a computer via the USB port or serial port. When connected through a USB 2.0 or 1.1 port, the spectrometer draws power from the host computer, eliminating the need for an external power supply. The Flame, like all Ocean Optics USB devices, can be controlled by our OceanView software (see [About OceanView](#)).

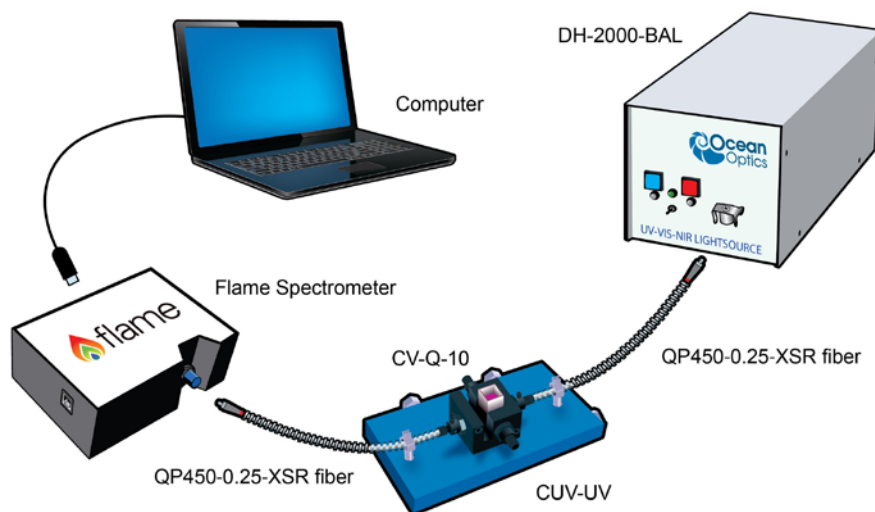

Ocean Optics Flame Fiber Optic Spectrometer Typical Set-up

Follow the steps below to connect the Flame to a computer via the USB port:

1. Install the spectrometer operating software on the destination computer.
2. Locate the USB cable (CBL-MICROTOA-USB) provided with the Flame.
3. Insert the micro connector end of the cable into the side of the Flame and the larger end of the cable into the USB port of the computer.
4. Connect any spectroscopy accessories. To find operating instructions for Flame-compatible products (such as light sources, sampling chambers, and probes), consult the Ocean Optics website at <http://oceanoptics.com/support/technical-documents/>.
5. Attach the fiber to the fiber optic connector on the spectrometer.

If you installed the spectrometer operating software prior to connecting the Flame, the software automatically installs the Flame drivers. If the drivers do not successfully install (or if you connected the Flame to the computer before installing the software), consult Chapter 4: [Troubleshooting](#).

Note

The Flame driver appears as USB2000+ to your computer since a common driver is used to ensure backwards and forwards compatibility. This does not affect functionality.

Hardware Features

Flame LEDs

The Flame features two indicator lights that operate as shown below:

LED	Steady	Flashing
red	Unit is on	N/A
green	Unit is ready	Unit is acquiring data

Note that LEDs can be turned off in OceanView or by using a firmware command.

Change the Slit

The Flame allows you to change your spectrometer’s slit to match your application requirements. Note that a filter must be ordered for each slit (if your application requires a filter). There’s no need to calibrate your spectrometer when changing the slit, just install and start measuring!

► **Procedure**

1. Find the SMA connector. If a fiber is attached, remove it.



2. Use the Allen key to remove the 2 the screws attaching the slit to the spectrometer.
3. Pull the slit out of the spectrometer.

2: Installation and Setup

- Put the new INTSMA slit connector into the spectrometer; with the key of the connector on the left side.

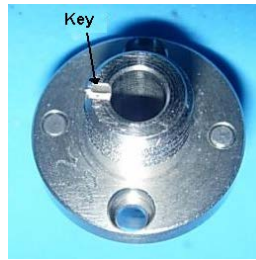

- Install the 2 screws again. Use the Allen key to tighten the screws carefully (do not over-tighten).
- If necessary, connect the fiber again.

Accessories

Ocean Optics provides a range of standard cables and accessories that connect the Flame to our large range of sampling and light source accessories. Items specifically designed for the Flame are described here; they are not provided with the Flame spectrometer and must be purchased separately. Visit us at www.oceanoptics.com for a complete list of products available for all of your spectroscopy needs.

Cables and Connectors

Cables are available to connect your Flame Spectrometer to accessories:

- Accessory cable for light sources and other accessories (DB15 Connector Cable)
- Accessory cable for HR-type connector (PAK50 Connector Cable)
- Breakout board (DD4 -BREAKOUT-BOARD) This breaks out the 40 pin DD4 connector to a set of header pins that can be used to wire each pin, as required.

DB15 Connector Cable (FLAME-CBL-DD4P-DB15P)

This cable connects the Flame to existing Ocean Optics accessories that use a DB-15HD connector. These include the PX-2, LLS and HL-2000-FHSA light sources.

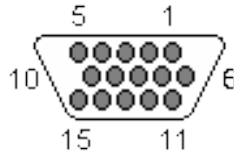

DD4-DB15 Pin Connections

15 PIN	DD4	Name
1	4	Single Strobe
2	3	Continuous Strobe
3	40	Vusb
4	2	External Trigger In
5	2	External Trigger In
6	7	GPIO 1
7	NC	Reserved (NC)
8	2	External Trigger In
9	8	GPIO 2
10	1	Ground
11	22	I2C SDA
12	21	I2C SCL
13	5	Lamp Enable
14	NC	Reserved (NC)
15	11	GPIO 4

PAK50 Connector Cable (FLAME-CBL-DD4P-PAK50P)

This cable connects the Flame to the [Breakout Box](#).

DD4P to PAK50P 30-Pin Connections

PAK50P	DD4	Name	PAK50P	DD4	Name
1	25	RS232 Rx	16	11	GPIO 4
2	24	RS232 Tx	17	4	Single Strobe
3	8	GPIO 2	18	12	GPIO 5
4	40	VUSB	19	16	SPI CLK
5	1	GND	20	3	Continuous Strobe
6	21	I2C SCL	21	18	SPI CS
7	6	GPIO 0	22	13	GPIO 6
8	22	I2C SDA	23	28	Reset
9	7	GPIO 1	24	NC	Reserved (NC)
10	2	External Trigger In	25	5	Lamp Enable
11	9	GPIO 3	26	14	GPIO 7
12	40	VUSB	27	10	GND
13	17	SPI MOSI	28	NC	Reserved (NC)
14	40	VUSB	29	15	GND
15	19	SPI MISO	30	NC	Reserved (NC)

For the DD4, connect shield to connector case, if shield is included.

Breakout Box (HR4-BREAKOUT)

The Breakout Box is a passive module that separates the signals from the Flame's DD4 40-pin connector to an array of standard connectors and headers, enabling functionality with a wide range of accessories. In addition to the accessory connector, the breakout box features a circuit board based on a neutral breadboard pattern that allows custom circuitry to be prototyped on the board itself. See [Product-Related Documentation](#) to access the manual for the Breakout Box.

Interchangeable Slits

The Flame offers the capability of changing the slit size to match your measurement needs. You can order additional replacement slits either individually or as a kit (in various widths from 5 μm to 200 μm). See [Change the Slit](#) and Chapter 5: [How the Flame Spectrometer Works](#) for more information.

Light Sources, Cuvette Holders and Other Accessories

Ocean Optics supplies a large range of accessories for use with our spectrometers. Visit us at www.oceanoptics.com for a complete list of products available for all of your spectroscopy needs.

- ❑ Fibers
- ❑ Light Sources
- ❑ Integrated Sampling Systems
- ❑ Cuvettes, including microfluidic cuvettes
- ❑ Filter Holders & Filters including Low Pass, Band Pass and High Pass

Measurement Techniques – Typical Set-ups

The Flame, in conjunction with Ocean Optics light sources and sampling accessories, can be used for many different measurement techniques. One of the key advantages of modular fiber optic spectroscopy is that you can change components of the system without having to buy a whole new system. Here, we show a range of typical UV-Vis set ups for basic spectroscopy techniques. You'll find lots more information about measurement techniques at www.oceanoptics.com/measurementtechnique.

Absorbance

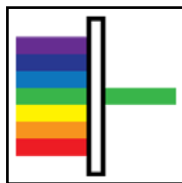

Below is a typical absorbance set up shown with a cuvette and a broadband light source. Flow cells can be used interchangeably with the cuvette holder for liquid or gaseous samples. Absorbance is typically a relative measurement, comparing the spectrum from the sample to a reference. Absorbance is commonly used for concentration measurements.

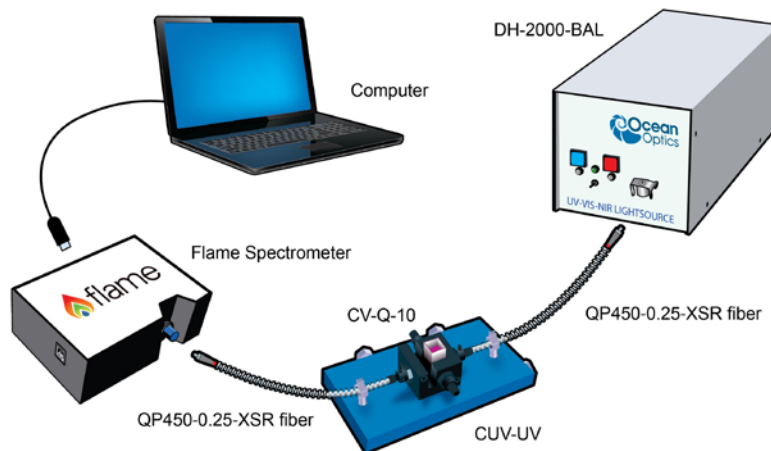

Typical Absorbance Set Up

Common UV-Vis Applications

- Quantification of DNA & proteins in life science samples
- Concentration of solutions & gaseous samples
- Identification of trace gases in a mixture

Reflectance and Transmission

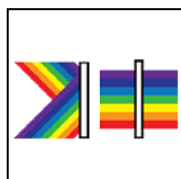

Reflectance spectroscopy compares the relative level of light (in %) reflected off a sample relative to a reference. Typically a reflectance standard is used to set the reference level of 100%. Transmission is similar but compares the light transmitted through a sample rather than reflected off it. Typically Reflectance uses a fiber optic probe attached to a light source and a spectrometer. Transmission measurements may use a transmission probe, cuvettes or flow cells, similar to absorbance measurements.

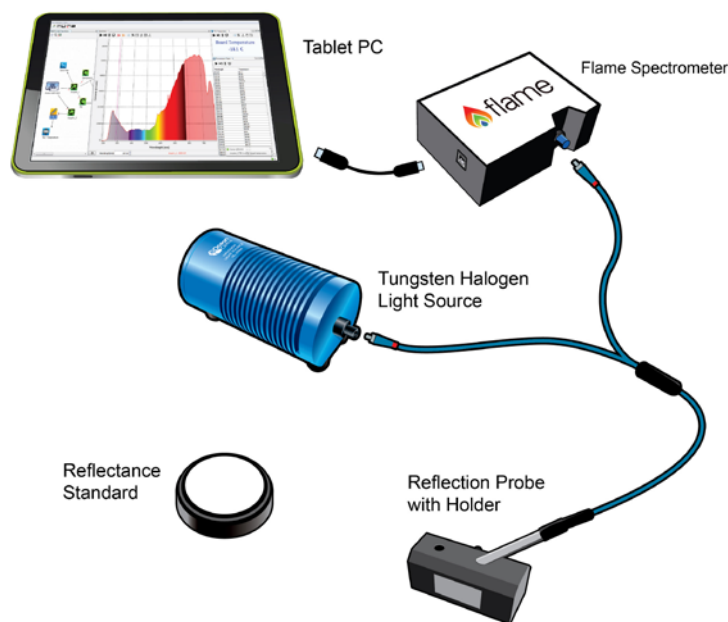

A Reflectance Set Up with Probe, Reflectance Standard and Probe Holder

Common UV-Vis Reflectance Applications

- Diffuse and Specular Color Measurements
- Process control for Surface quality of metals
- Thin film and semiconductor metrology

Common UV-Vis Transmission Applications

- Turbidity measurements of chemical solutions
- Measuring the transmission efficiency of optics and glass

Fluorescence

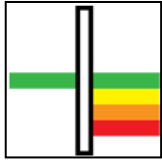

Fluorescence is a technique where a sample is excited with a light source and fluorescent light emitted from the sample at a higher wavelength is measured by the spectrometer. Typically the excitation source is applied at 90° to the sample to minimize light from the excitation source reaching the spectrometer. Similarly filters are used to block lower wavelength light from reaching the detector. Spectrometers used for fluorescence typically have a large slit, sacrificing resolution for throughput sensitivity.

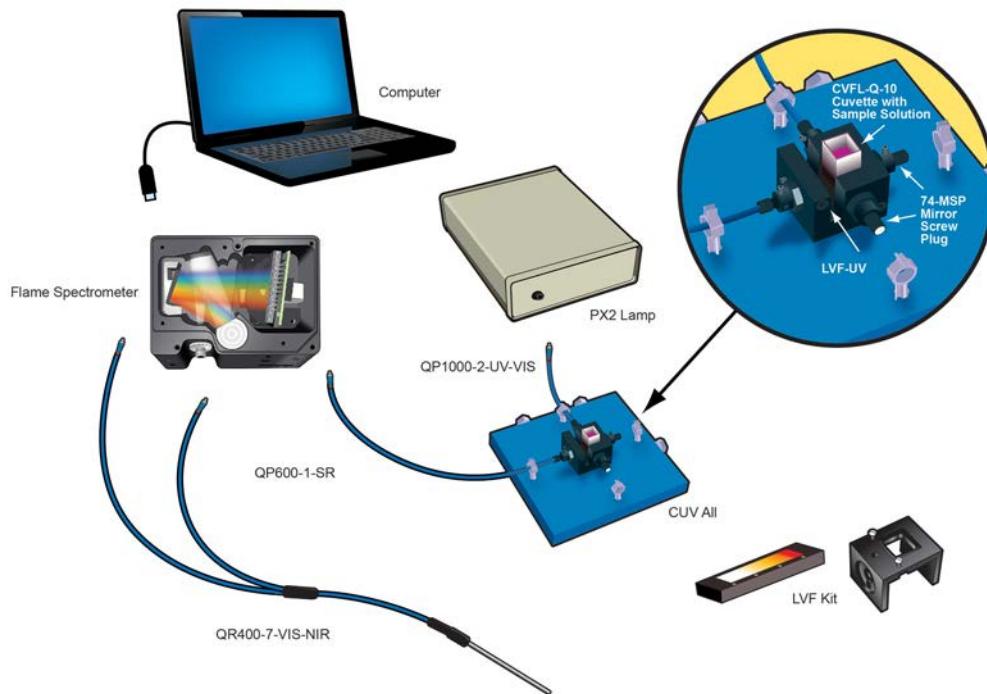

Typical Fluorescence Set Up with an LED Excitation Source at 90°

Common Fluorescence Applications

- Identifying proteins using fluorophores
- NADH fluorescence
- Remote sensing of chlorophyll
- Medical diagnosis of tumors and tissue types
- Detection of anti-counterfeiting tags

Irradiance

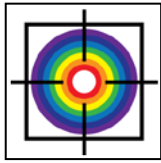

Irradiance is the technique of measuring the total energy of the light vs. wavelength either relative to the output of a known source (relative irradiance) or in absolute units of power or energy (absolute irradiance). This is used widely in light metrology, color measurement and environmental science. Absolute irradiance measurements require an irradiance-calibrated spectrometer. This can be done in the factory for fixed configurations or by using a calibration lamp in the lab or field. Every time a set-up is changed, it must be recalibrated.

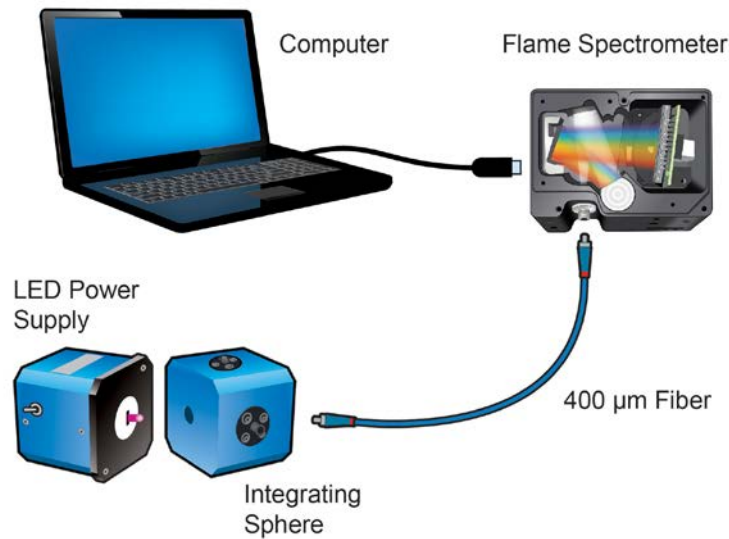

Typical Relative Irradiance Set-up for Measuring Light Power Output of an LED Using and Integrating Sphere

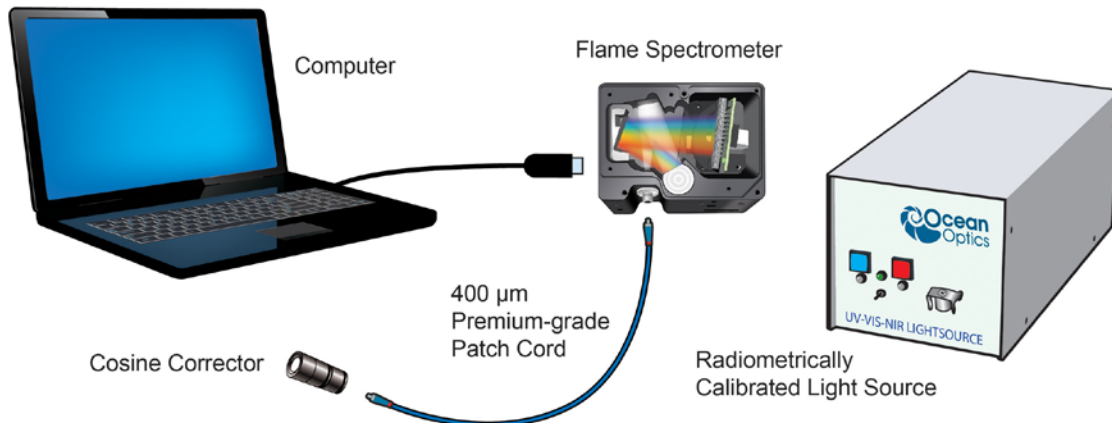

Typical Set-up for an Absolute Irradiance Measurement Using Field Calibration with a Calibrated Light Source

Common Irradiance Applications

- Measuring the radiant output of lamps and LEDs
- Measuring color using relative irradiance
- Measuring the color rendering index (CRI)
- Measuring UV exposure for health and safety

Flame Operation with OceanView

Overview

The following information enables you to perform the basics of acquiring and saving data with your Flame Spectrometer and OceanView software. More detailed information about OceanView is in the OceanView Manual (see [Product-Related Documentation](#)).

Launch OceanView

Once you have installed your software and connected your spectrometer, you are ready to display your measurement data using OceanView. Launching OceanView differs, depending on your operating system and where you have placed your OceanView program files.

For PCs running Microsoft Windows, the default location is Start | Programs | Ocean Optics | OceanView | OceanView.

For Mac computers, the default location is the Applications folder.

When you first start OceanView, the Welcome screen appears.



OceanView Welcome Screen—Version 1.5

Select from the following tasks:

- **Quick View** -- Displays the spectrum in Quick View mode showing raw, unprocessed data. This is uncorrected for instrument response vs. wavelength. Quick View shows you a live shot of what the spectrometer is “seeing.” From Quick View you can launch application wizards or construct your own method.

3: Operation

- **Load a Saved Project** – Loads a previously saved project. Click **Restore Last Session** to reload the schematic and views as they were when the software was last closed.
- **Spectroscopy Application Wizards** – Use this function to set up a measurement using simple step-by-step wizards. A large range of applications is available.

OceanView Main Screen

No matter what route you take on start up, you will soon end up on the OceanView main screen. This is where you can set and view acquisitions, save and load data and save projects.

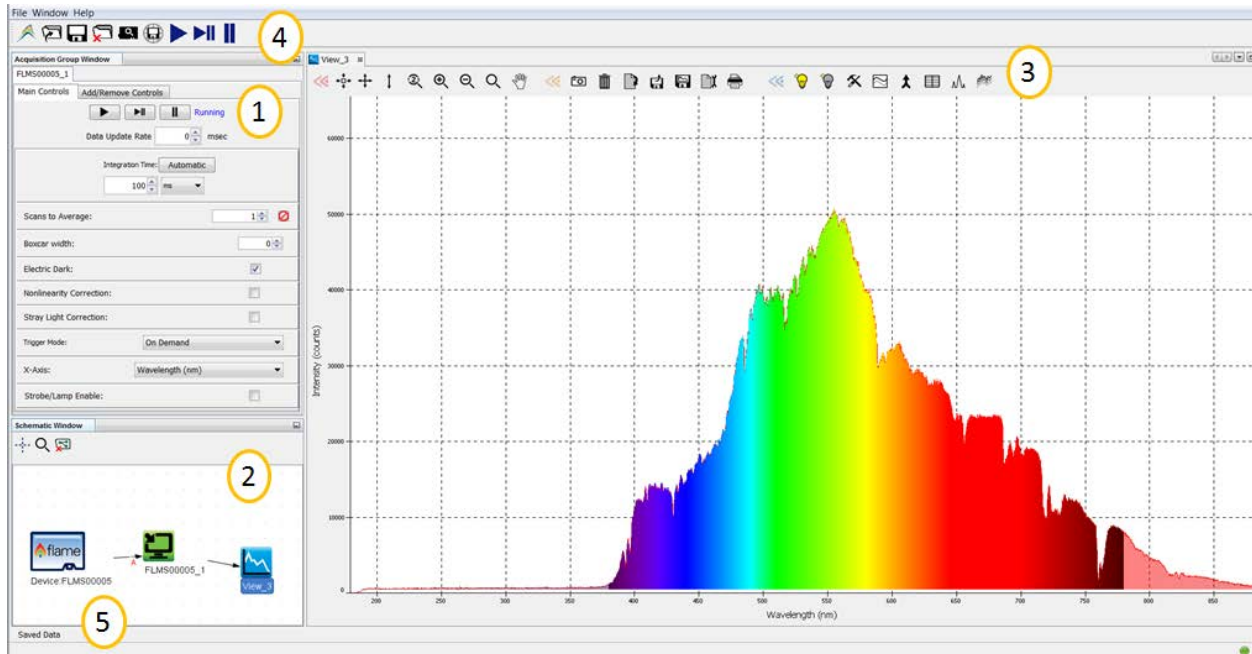

1. Acquisition Group Window	Use to set acquisition parameters such as integration time. Controls the spectrometer acquisition.
2. Schematic View	Schematic view graphically displays the flow of information from the spectrometer to the view. Use nodes to mathematically modify the data to create processed measurements (methods). This function is extremely flexible and incredibly powerful.
3. View Display	Display your data, view, save and display controls, as well as other features such as peak finder and quick dark & reference.
4. Global Controls	Control all spectrometers synchronously, save projects, and start a new application wizard.
5. Saved Data	Displays data saved in the active save file path. Preview data, store notes and load overlays directly to the active view. Click to open.

Connect the Flame in OceanView

The Flame should automatically appear when you start OceanView and should be acquiring with the default acquisition parameters. If you do not see a signal or the Flame icon on the schematic you may need to rescan for spectrometers.

► Procedure

To rescan for attached devices,

1. Click on the Device Manager icon ().
2. Click Rescan. The spectrometer should automatically connect.

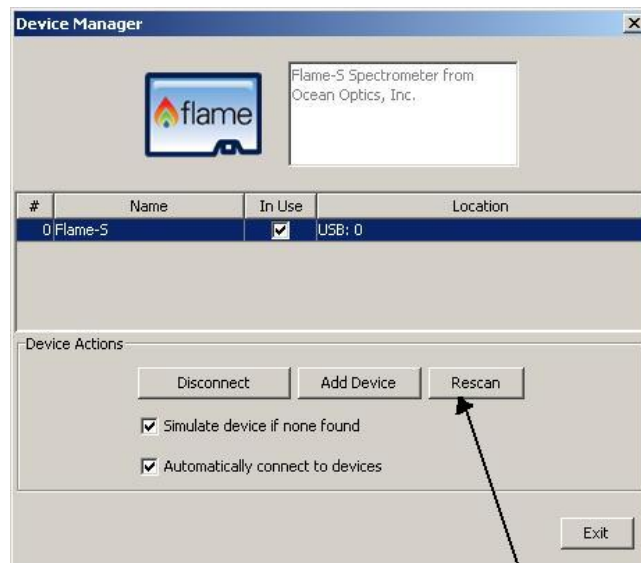

Rescan Button

Set Acquisition Parameters

Set Acquisition parameters in the Acquisition Group Window to control the spectrometer. This window may be minimized when you first start OceanView. You can either expand or open a new window from the menu (Window | Acquisition Group). An active acquisition is required for the Acquisition window to appear. Functions available to control in the Acquisition window include the following:

- **Integration Time** – Sets the integration time, the time over which the detector captures incident light. At the end of the integration time the accumulated signal is read from the detector by the electronics.
- **Averaging** – Signal, especially at low levels, is often significantly impacted by noise. Averaging several spectra together reduces the impact of noise and provides a cleaner result. However, at long integration times, averaging can increase the total time of a measurement significantly.

- **Boxcar** – Boxcar is a form of averaging across pixels. It applies a rolling average to multiple adjacent pixels to help smooth the spectral response and reduce the impact of noise.
- **Electric Dark Correction (on/off)** – There are pixels on the detector that are kept deliberately dark. Dark correction subtracts the signal from these dark pixels to reduce the impact of thermal noise, which produces a baseline signal from the detector.
- **Non Linearity Correction (on/off)** – Detectors do not have a completely linear response. As they approach saturation, typically their efficiency reduces.
- **Stray Light Correction** – An advanced user option that allows you to set a 1 or 2-term polynomial correction for stray light correction.
- **Trigger Modes** – Sets triggering mode. For more information on triggering see [External Triggering](#).
- **Strobe/ Lamp (on/off)** – Use this function to turn an attached light source on or off.
- **GPIO Controls** – Can be used to control compatible accessories or custom hardware. Can be set to three states, on, off and alternate.

Controls that appear in this window depend on the spectrometer model. You can add and remove acquisition controls from this window.



Quick View and Device Response

In **Quick View mode** (formerly called **Scope mode**), the spectra that are displayed have an arbitrary y-axis given in counts. This is the raw signal from the detector and is proportional to the voltage induced by the light falling on the detector.

It is very important to realize that this is uncalibrated data and that a counts signal does not represent a particular power or energy from one wavelength to the next. Because the response of the detector is linear, twice the counts at a particular wavelength do indicate that the amount of light at that wavelength has “doubled” (relative to another wavelength). However, a small peak relative to a big peak does not indicate that there is less or more light at a particular wavelength relative to another in absolute terms. To understand the true relationship you need to do a relative measurement (including relative irradiance), or if you want a quantified result, an absolute irradiance measurement.

Continuous and Single Acquisitions

There are two sets of controls for taking or pausing acquisitions. The set on the Acquisition group window allows you to control each spectrometer individually. The set on the top bar is a global control that will allow you to start and pause all spectrometers currently attached.

	Acquire data continuously
	Take a single acquisition and then pause
	Pause all acquisitions

Save Data

	<p>Configure Saving, set saving parameters and file type, file directory and file naming convention. Once selected, the file directory will persist until changed.</p>
	<p>Start saving data. Turns red when save is active. If saving data continuously, click when red to stop saving. Will only activate saving for acquisitions attached to that particular view.</p>
	<p>Global Save. Activates all configured saves across all views. Use to save data from multiple spectrometers at the same time.</p>

By default OceanView will save data as a single “snapshot” acquisition. By configuring the save, you can set the save behavior to fit your measurement needs, from single snapshots to a continuous stream of data over time.

Saved Data Panel

The saved data panel lets you see your data as it is saved and preview data. It also makes it simple to add overlays of saved data to your active view.

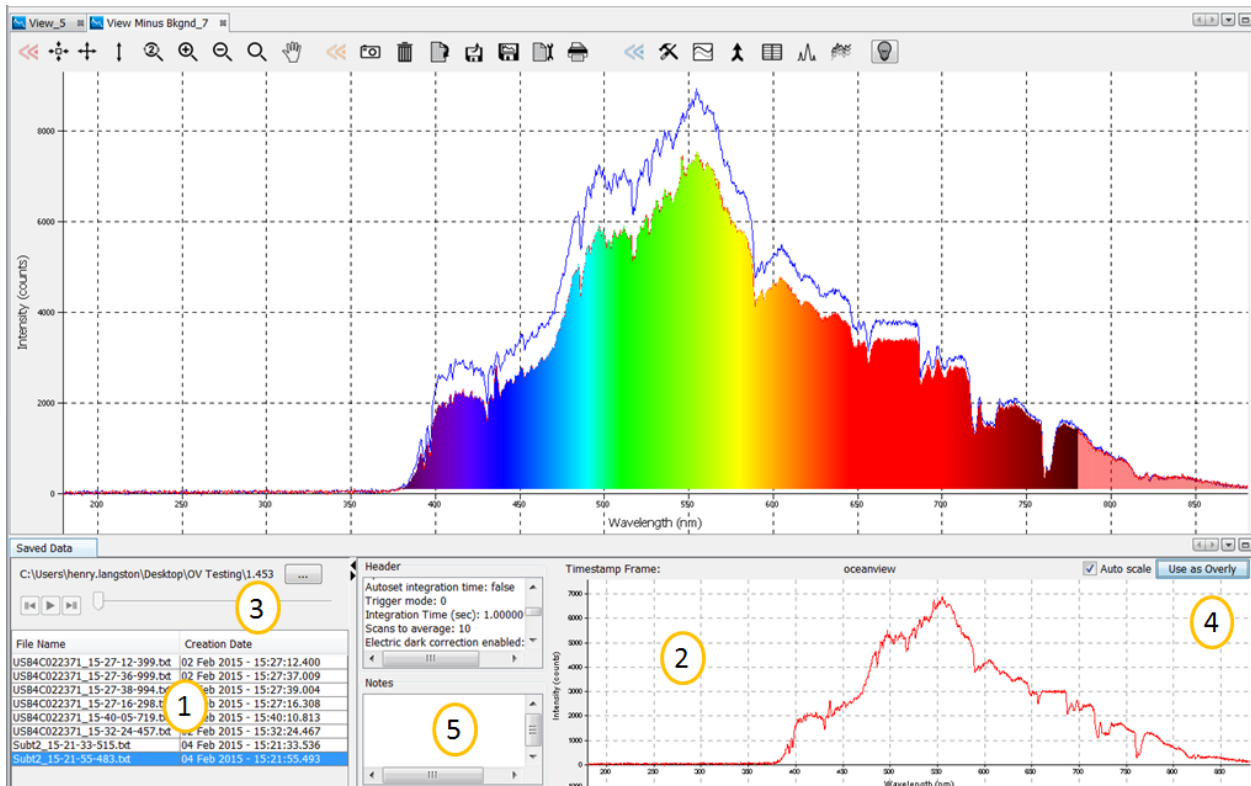



Saved Data Panel

3: Operation

1. Saved Files	List of saved files currently in the saved directory. Arrange by name or date.
2. Preview	Shows a preview of the saved spectra, time series or appended series saved data that can be stepped through, acquisition by acquisition, using the controls above the saved files list.
3. File Path	Set the file directory.
4. Overlay	Set the previewed spectra as an overlay on the active view.
5. Notes	Enter notes about the saved spectra. Notes are saved with the same file name as a separate .tsv file. These can be viewed or edited with any text viewer such as Notepad.

Projects and Methods

OceanView makes it easy to save and load projects and methods. We define a project as a measurement set up made with a particular spectrometer. If the software cannot find the spectrometer, it will load this as a method and prompt the user to select a substitute spectrometer from those selected.

	Click to save a project. Alternatively select <i>File Save Project</i> from the menu. Saves all view and schematic parameters to a single ASCII file.
	Load a project or method.

Spectroscopy Application Wizards

OceanView provides you with a wealth of functionality to capture, store and process your data. This chapter contains descriptions of wizards and other functionality. See your OceanView manual for more information on wizards.

	Click this button to set up a measurement using simple step-by-step wizards. A large range of applications is available.
---	--

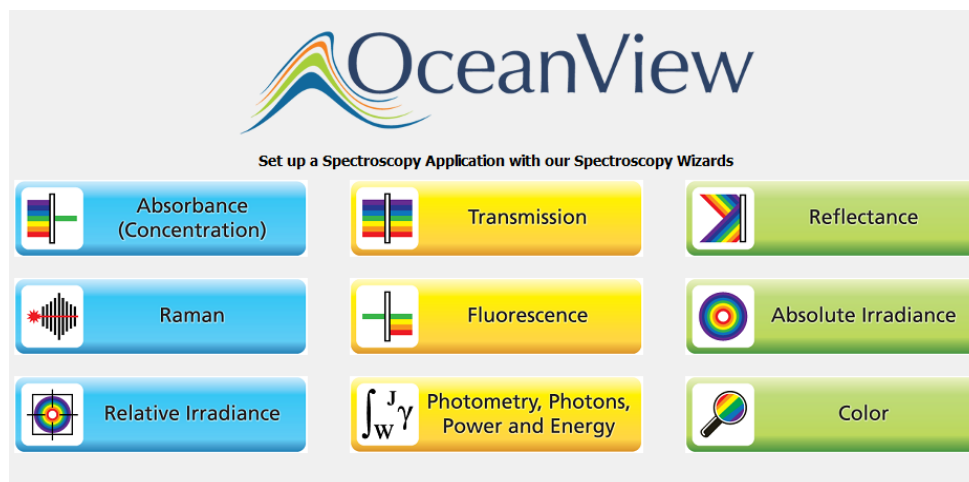

Application Wizard Window

Dark and Reference Measurements

Dark and reference measurements are commonly used in spectroscopy.

- **Dark Measurements** – Subtract a background signal from the spectrum. This can be considered the removal of a constant error. Typically this is done when the light source is off to remove any background from the ambient environment, hence the name dark.
- **Reference Measurements** – Make the signal relative to the reference. Consider this a normalization of the signal against a reference. Typically this is taken with a reference sample and the light source turned on. This lets you look at the relative spectral change when a sample interacts with the illumination source.

Most often you will set up your measurement with the reference and dark through the application wizards. The wizards will prompt you to take your reference and darks. Alternatively you can use the quick dark and quick reference features. Once a dark and/or reference measurement has been set, you can update it with the controls on the top bar of the view.



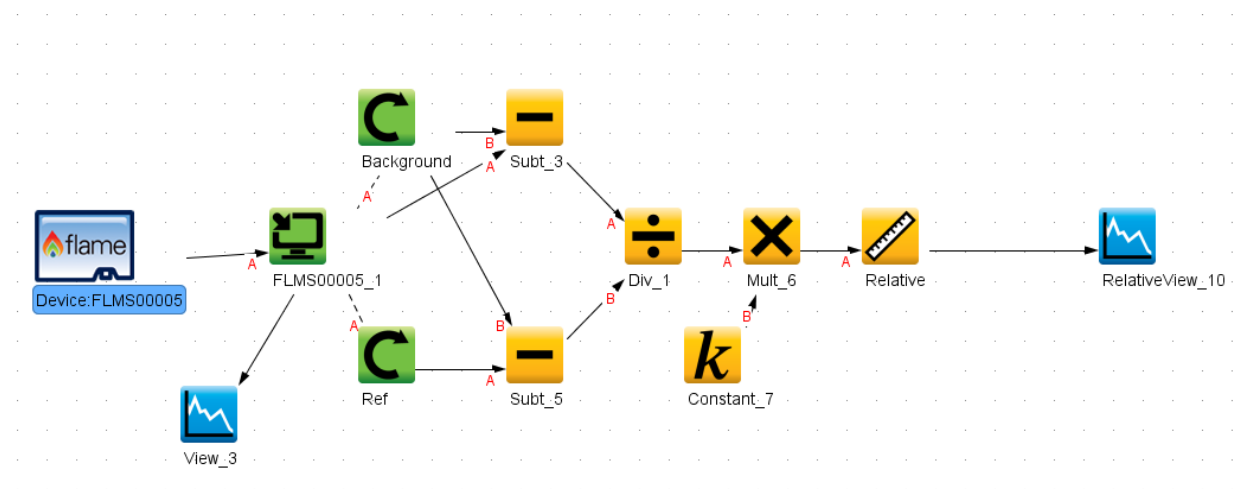

	Quick Reference – click to take a reference and set up a new view. After clicking it will prompt the user to take a dark. This will normalize the signal against the reference (in %).
	Quick Dark – click to take a dark measurement and sets up a new Quick View minus dark view.
	Reference – click to update the stored reference measurement.
	Dark – click to update the stored dark measurement.

Schematic View



3: Operation

The schematic view is a graphical interface that allows you to move from device through to processed data. There are a few basic components to consider.

 Device:FLMS00005	<p>Devices – Each spectrometer will appear as a separate device. Right click to open a menu that can generate an acquisition, control a TEC (if applicable) and add other device controls.</p>
	<p>Acquisitions – A spectrometer can output one acquisition per detector channel. Right click to open menu.</p>
 Mult_6	<p>Nodes – These are the building blocks of the schematic view. They are all various functions that take data in and provide an output. To make a node, right click on the schematic background. Each node can be configured by double clicking on the node. To join nodes press ctrl, click and drag (windows).</p>
	<p>Views – Are a type of window that displays data. To generate a new view right click on the schematic background.</p>

More information about schematic view including detailed descriptions of the available nodes can be found in the *OceanView Installation and Operation Manual* (see [Product-Related Documentation](#)) and in the help section of the OceanView software.

Troubleshooting

Overview

Sometimes things don't quite go to plan; hopefully you'll find some answers below. If not, don't hesitate to contact us and our Tech Support team will leap into action. Some typical questions are answered here. For more information, consult the FAQs on the Ocean Optics website at <http://oceanoptics.com/faq/>.

I connected the USB cable and started OceanView but I don't see my spectrometer attached.

Use the Rescan button in the Device Manager to rescan for attached devices.

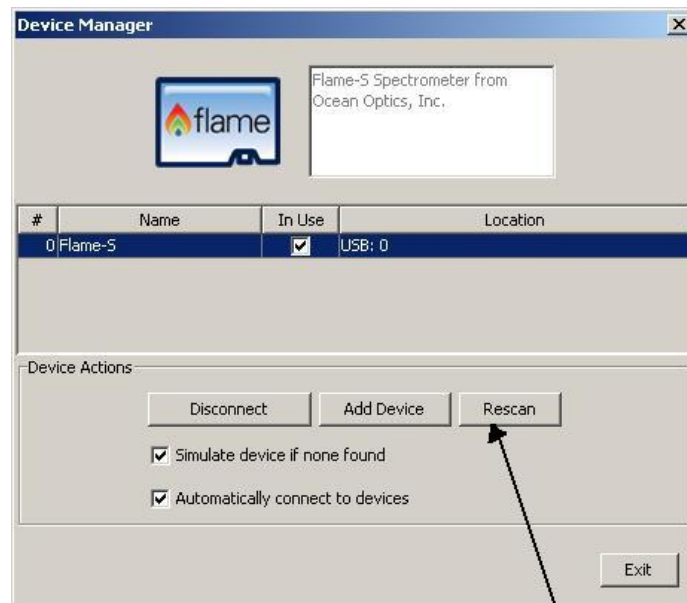

Rescan Button

I am having trouble installing the drivers, what should I do?

Hardware device driver installation is usually seamless on Microsoft Windows operating systems and should happen in the background when you connect your spectrometer to a computer with the software installed. However, some Windows systems require a bit more care when connecting your spectrometer for the first time.

If your spectrometer is not recognized by OceanView on your computer, you need to manually install the spectrometer drivers. See your OceanView manual for this procedure. Also consult the *Correcting Device Driver Issues* document (see [Product-Related Documentation](#)).

How do I know my spectrometer has power?

The red LED on the spectrometer should be on steadily if the unit is receiving power.

How do I know my spectrometer is transmitting data?

The green LED on the spectrometer flashes when transmitting data.

I'm installing OceanView but I need a product key; where can I find this?

The product key was sent to the contact e-mail on the sales order when you purchased your OceanView license. Contact info@oceanoptics.com for more information. You'll need your sales order number, quotation number, the serial number of the spectrometer that was purchased with the software, and, if known, the e-mail address under which your product key was created to recover your key.

I connected the Flame to the computer before installing my spectroscopy operating software to install the drivers. What do I do now?

The steps to take to resolve this issue differ, depending on your computer's operating system.

Microsoft Windows Operating Systems

If you connected your Ocean Optics Flame device to the computer prior to installing your Ocean Optics software application on a Windows platform, you may encounter installation issues that you must correct before your Ocean Optics device will operate properly.

Follow the applicable steps below to remove the incorrectly installed device, device driver, and installation files.

Note

If these procedures do not correct your device driver problem, you must obtain the *Correcting Device Driver Issues* document from the Ocean Optics website: <http://oceanoptics.com/wp-content/uploads/Correcting-Device-Driver-Issues.pdf>.

Remove the Unknown Device from Windows Device Manager

► Procedure

1. Open Windows Device Manager. Consult the Windows operating instructions for your computer for directions, if needed.
2. Locate the **Universal Serial Bus Devices** option and expand the **Universal Serial Bus Devices** selection by clicking on the "+" sign to the immediate left.

Note

Improperly installed USB devices can also appear under the Universal Serial Bus Controller option. Be sure to check this location if you cannot locate the unknown device.

3. Locate the unknown device (marked with a large question mark). Right-click on the **Unknown Device** listing and select the **Uninstall** or **Remove** option.
4. Click the **OK** button to continue. A warning box appears confirming the removal of the Unknown Device. Click the **OK** button to confirm the device removal.
5. Disconnect the Flame from your computer.
6. Replug the spectrometer into your computer.

The system should now be able to locate and install the correct drivers for the USB device.

Apple Mac OSX Operating Systems

Since there are no device files for the Flame Spectrometer in a Mac operating system, you should not encounter any problems if you installed the spectrometer before the spectrometer operating software.

Linux Operating Systems

For Linux operating systems, all you need to do is install the spectrometer operating software, then unplug and replug in the spectrometer. Technically, the driver files for Linux simply give nonprivileged users permission to use newly connected hardware. There isn't any long-term harm to plugging in the device before installing the software.

I have both SpectraSuite and OceanView installed. Will my spectrometer work with both?

Yes. There should be no driver issues with Windows 64-bit, Mac, and Linux operating systems since they all use the **winusb** driver. For Windows 32-bit systems, you will need to swap the drivers when switching software since OceanView uses the **winusb** driver, while SpectraSuite uses the **ezusb** driver.

How do I determine whether my Windows computer is 32-bit or 64-bit?

Errors can occur if you download the wrong version of software (for 32-bit or 64-bit computers). To verify your computer version for most Windows computers, go to the Properties window (under Computer or My Computer). If no version is listed, then your system is a 32-bit. For more information see the Microsoft Frequently Asked Questions at <http://windows.microsoft.com/en-us/windows/32-bit-and-64-bit-windows#1TC=windows-7>.

How do I check the configuration of my spectrometer?

Check the label on the bottom of your spectrometer. You can also check your configuration using your spectrometer operating software.

For OceanView: Open the Schematic window and double click the spectrometer icon.

For SpectraSuite: Click the plus (+) icon next to the spectrometer to open properties and configuration.

Product Upgrades, Repairs and Servicing

Occasionally, you may find that you need Ocean Optics to make a change or an upgrade to your system. To facilitate these changes, you must first contact Customer Support and obtain a Return Merchandise Authorization (RMA) number. Please contact Ocean Optics for specific instructions when returning a product.

Repairs

Sometimes accidents happen! If you need to return your Ocean Optics Product for repair, here is what to do:

► **Procedure**

1. Contact us to speak to an Ocean Optics representative about the problem. If it is determined that the product must be returned, the representative will issue an RMA number.
2. Package your product, ideally in the original packaging, and return it to Ocean Optics, along with the RMA number that you received.

Note

For RMA returns under warranty we will organize and pay for shipping both ways. For accidental damage, you only pay to have the product delivered to your closest Ocean Optics or OOI Distributor Office.

Upon careful examination, we'll advise you with an estimate. When your product is ready, it will be returned to you.

Servicing

To keep your instrument in tip top shape we recommend yearly wavelength recalibration. You can do this yourself if you have appropriate tools or we can do this for you. Contact your local representative to find out more about service availability and cost. We offer the following services:

- Wavelength Calibration
- Absolute Irradiance Calibrations

How the Flame Spectrometer Works

Overview

This section provides an overview of the Flame spectrometer and how it works from light entering the slit through to the transmission of the spectrum over USB. It also provides an overview of all the different possible configurations that are possible, designed to help you optimize your spectrometer for specific applications.

You'll find more useful information, including a [glossary of spectroscopy and spectrometer terms](#), on our website at www.oceanoptics.com.

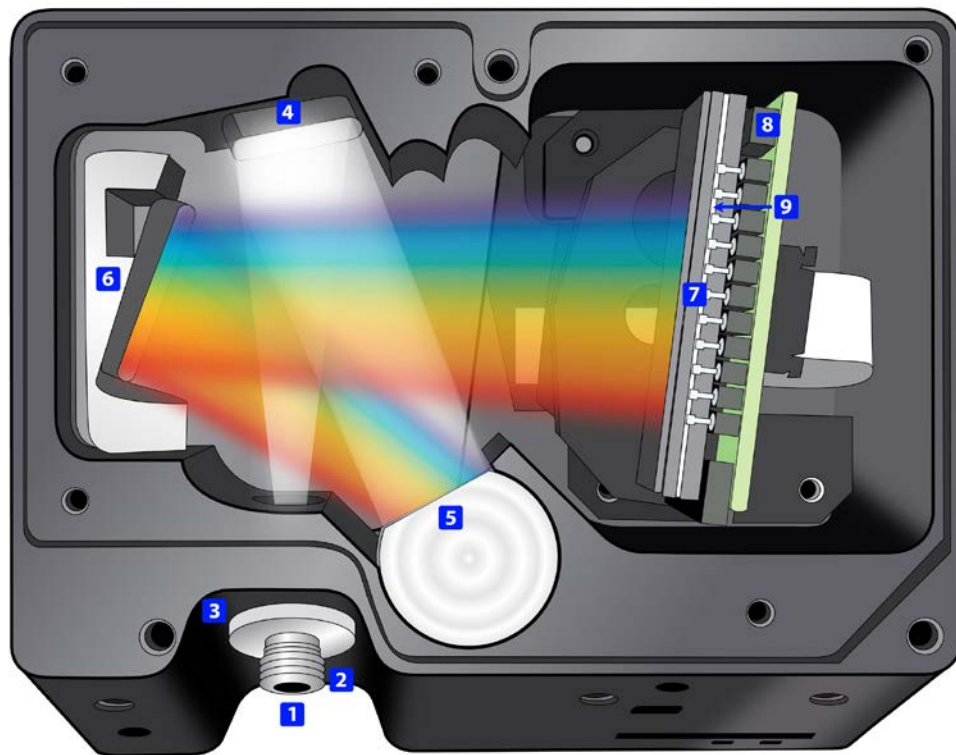

Flame Open Bench

1. **Fiber Optic Connector:** Light from a fiber enters the optical bench through the SMA 905 Connector. The SMA 905 bulkhead provides a precise location for the end of the optical fiber, slit, absorbing filter and fiber clad mode aperture. While we supply SMA connectors as standard, FC connectors are also available. See #2 for available options.
2. **Interchangeable Slit:** Light passes through the installed slit, which acts as the entrance aperture. Slits come in various widths from 5 μm to 200 μm . The slit is fixed in the SMA 905 bulkhead to sit against the end of a fiber. Smaller slit sizes achieve the best optical resolution while larger slits have higher light throughput. Slit size is labeled as shown.



Slit	Description	Pixel Resolution
INTSMA-5	5- μm wide x 1-mm high	~3.0 pixels
INTSMA-10	10- μm wide x 1-mm high	~3.2 pixels
INTSMA-25	25- μm wide x 1-mm high	~4.2 pixels
INTSMA-50	50- μm wide x 1-mm high	~6.5 pixels
INTSMA-100	100- μm wide x 1-mm high	~12 pixels
INTSMA-200	200- μm wide x 1-mm high	~24 pixels
INTSMA-000	Interchangeable bulkhead with no slit	NA
INTSMA-KIT	Interchangeable SMA Kit connectors; 5 μm ; 10 μm ; 25 μm ; 50 μm ; 100 μm and 200 μm	NA

Ocean Optics also offers a range of FC connector slits in the same wavelengths, with the product code INTFC-XXX. An INTFC-KIT is also available. Note that these items are made to order and have a longer lead time. Contact an Ocean Optics Application Sales Engineer for more details.

► **Procedure**

To calculate the optical resolution for your spectrometer,

1. Find the number of pixels for your detector.
2. Divide the range of the spectrometer by the number of pixels.
3. Multiply this number by the pixel resolution from the table above.

For example: Resolution of the Flame-S with a 50 μm slit and 650 nm range
 $650/2048 \times 6.5 = 2.1 \text{ nm}$

3. **LongPass Absorbing Filter (optional):** If selected, an absorbing filter is installed between the slit and the aperture in the SMA 905 bulkhead. The filter is used to limit bandwidth of light entering spectrometer or to balance color. Filters are installed permanently. A filter is for a specific slit. If you anticipate needing the filter with multiple slit sizes, then you must specify this at the time you order. You will know which filter is installed in each slit because of the color-coded dots on the outside as shown in the figure and described in the table below.



Item Code	Description	Dot 1	Dot 2
OF1-BG28	Bandpass filter, transmits >325 and <500 nm	blue	red
OF1-WG305	Longpass filter; transmits light >305 nm	black	white
OF1-U325C	Bandpass filter, transmits >245 and <390 nm	white	green
OF1-GG375	Longpass filter; transmits light >375 nm	red	black
OF1-GG395	Longpass filter; transmits light >395 nm	white	red
OF1-CGA420	Longpass filter; transmits light >420 nm	orange	white
OF1-GG475	Longpass filter; transmits light >475 nm	green	green
OF1-OG515	Longpass filter; transmits light >515 nm	pink	yellow
OF1-OG550	Longpass filter; transmits light >550 nm	orange	orange
OF1-OG590	Longpass filter; transmits light >590 nm	red	pink
OF1-RG695	Longpass filter; transmits light >695 nm	white	blue
OF1-RG830	Longpass filter; transmits light >830 nm	black	blue
OF1-CGA1000	Nonfluorescing longpass filter, transmits >1000 nm	red	green
OF1-CGA760	Nonfluorescing longpass filter, transmits >760 nm	blue	black
OF1-CGA780	Nonfluorescing longpass filter, transmits >780 nm	white	yellow
OF1-CGA830	Nonfluorescing longpass filter, transmits >830 nm	green	orange
OF1-CGA475	Nonfluorescing longpass filter, transmits >475 nm	yellow	pink

4. **Collimating Mirror (specify Standard or SAG+):** The collimating mirror is matched to the 0.22 numerical aperture of our standard optical fibers. Light reflects from this mirror, as a collimated beam, toward the grating. You can opt to install a standard mirror or a NIR-enhancing but UV absorbing SAG+ mirror.
- SAG+ mirrors are often specified for fluorescence. These mirrors absorb nearly all UV light, which reduces the effects of excitation scattering in fluorescence measurements. Unlike typical silver-coated mirrors, the SAG+ mirrors won't oxidize. They have excellent reflectivity — more than 95% across the VIS-NIR.

Specify standard or SAG+ mirrors when ordering your spectrometer.

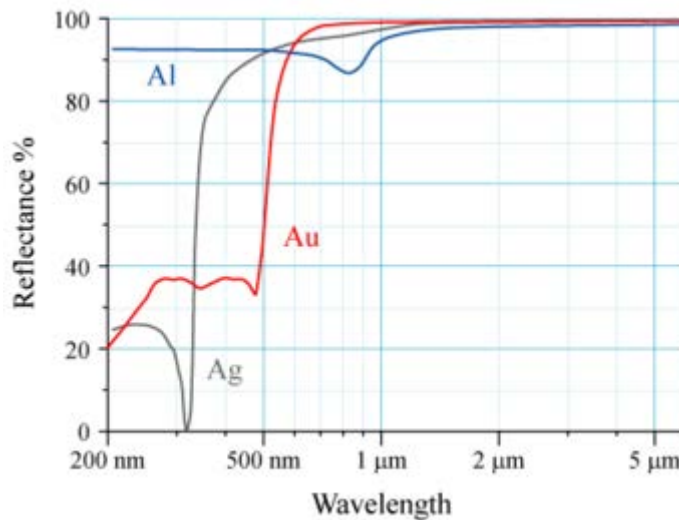

Reflectance vs. Wavelength for Aluminum, Gold, and Silver Mirrors

By Bob Mellish in Wikipedia

- Grating and Wavelength Range (specify grating and starting wavelength):** We install the grating on a platform that we then rotate to select the starting wavelength you have specified. Then we permanently fix the grating in place to eliminate mechanical shifts or drift.

Use our online [Range and Resolution Calculator](#) to find out how your grating choice affects spectral range and optical resolution by viewing the grating efficiency curves. The available gratings are summarized below:

Grating Number	Intended Use	Groove Density	Spectral Range	Blaze Wavelength	Best Efficiency (>30%)
1	UV	600	650 nm	300 nm	200-575 nm
2	UV-VIS	600	650 nm	400 nm	250-800 nm
3	VIS-Color	600	650 nm	500 nm	350-850 nm
4	NIR	600	625 nm	750 nm	530-1100 nm
5	UV-VIS	1200	300 nm	Holographic UV	200-400 nm
6	NIR	1200	200-270 nm	750 nm	500-1100 nm
7	UV-VIS	2400	100-140 nm	Holographic UV	200-500 nm
9	VIS-NIR	1200	200-270 nm	Holographic VIS	400-800 nm
10	UV-VIS	1800	100-190 nm	Holographic UV	200-635 nm
11	UV-VIS	1800	120-160 nm	Holographic VIS	320-720 nm

Grating Number	Intended Use	Groove Density	Spectral Range	Blaze Wavelength	Best Efficiency (>30%)
12	UV-VIS	2400	50-120 nm	Holographic VIS	260-780 nm
14	NIR	600	625 nm	1000 nm	650-1100 nm
31	UV-NIR	500	200-1025 nm	250 nm	200-450 nm

Grating efficiency curves are available to view by using our online range and resolution calculator at www.oceanoptics.com/product-category/modular-spectrometers/.

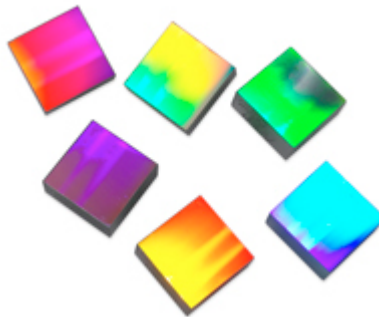

Gratings Showing Light Diffracted into its Constituent Wavelengths

6. **Focusing Mirror (specify standard or SAG+):** This mirror focuses first-order spectra on the detector plane. Both the collimating and focusing mirrors are made in-house to guarantee the highest reflectance and the lowest stray light possible. You can opt to install a standard or SAG+ mirror. As with the collimating mirror, the mirror type needs to be specified when ordering.
7. **Detector Collection Lens (optional):** This cylindrical lens is fixed to the detector to focus the light from the tall slit onto the shorter detector elements. It increases light-collection efficiency and reduces stray light. It also is useful in a configuration with a large-diameter fiber and slit for low light-level applications such as fluorescence. Preconfigured Flame spectrometers with a collector lens are available – look for –ES at the end of the name.

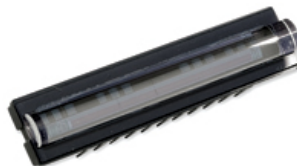

8. **Detector:** There are two choices of detector available for the flame. We offer a 2048-element FLAME-S (Sony ILX511B) or a 3648 element FLAME-T (Toshiba TCD1304AP) linear CCD array. These both have an effective range of 190-1100 nm. The optics split the light into its component wavelengths which fall across the different

pixels. Each pixel responds to the wavelength of light that strikes it. The detector outputs an analog signal from each pixel that is converted via the ADC into a digital signal. The driver electronics process this signal and send the spectrum via the USB connection to the software. The best choice of detector will depend on the application.

Detector Specifications

Specification	S Type (FLAME-S)	T Type (FLAME-T)
Detector	Sony ILX511B linear silicon CCD array	Toshiba TCD1304AP linear silicon CCD array
Strengths	<ul style="list-style-type: none"> • Strong response < 350nm, good for UV measurements. • Fast data output rate. • Larger pixel size improves sensitivity 	<ul style="list-style-type: none"> • Slightly higher SNR due to well depth • Larger number of pixels can offer better resolution with small slits. • Electronic shutter
Watch for	N/A – Offers strong all-around performance	<ul style="list-style-type: none"> • Signal lag at low integration times • Signal may bleed to neighboring pixels at high intensities (blooming) • Higher minimum integration time

See Chapter 6: [Technical Specifications](#) for more detailed detector specifications.

9. **OFLV Variable Longpass Order-sorting Filter (optional):** Our proprietary filters precisely block second- and third-order light from reaching specific detector elements. Light reflected off the grating can propagate 2nd and 3rd order effects at whole multiples of the incident light. While these signals are weak, they may cause stray light that reduces the accuracy of the spectrometer response. Order sorting filters reject this stray light only allowing the desired wavelength through to the detector. Order sorting filters are combined with detector window upgrades. The full range available is listed below. These must be specified at the time of ordering.

Detector Window Upgrades (optional): The standard BK7 glass window on the detector begins to absorb light around 340nm. For applications in the UV, below 360nm, we recommend the detector window upgrade. This replaces the BK-7 glass with Quartz. Typically these are used in conjunction with an order sorting filter to block the impact of 2nd and 3rd order effects at higher wavelengths.

Available Order-Sorting and Detector Window Options

Detector	Description	Spectrometer
DET2B-200-535	Sony ILX511B detector, installed, with Custom OFLV Coated Window Assembly for Grating#5 and Grating#5U, S-bench	FLAME-S
DET2B-200-850	Sony ILX511 detector, installed, with 200 – 850 nm variable longpass filter and UV2 quartz window; best for UV-VIS systems configured with Grating #1 or #2	FLAME-S
DET2B-200-1100	Sony ILX511 detector, installed, with 200 – 850 nm variable longpass filter and UV2 quartz window; best for UV-VIS systems configured with XR-1 grating	FLAME-S
DET2B-350-1000	Sony ILX511 detector, installed, with 350 – 1000 nm variable longpass filter; best for VIS systems configured with Grating #2 or #3	FLAME-S
DET2B-UV	Sony ILX511 detector, installed, with UV2 quartz window; best for systems configured for <360nm	FLAME-S
DET2B-VIS	Sony ILX511 detector, installed, with VIS BK7 window; best for systems configured for >400nm	FLAME-S
DET4-200-535	Toshiba TCD1304AP detector, installed, with Custom OFLV Coated Window Assembly for Grating#5 and Grating#5U, S-bench	FLAME-T
DET4-200-850	Toshiba TCD1304AP detector, installed, with 200 – 850 nm variable longpass filter and UV2 quartz window; best for systems configured with Grating #1 or #2	FLAME-T
DET4-200-1100	Toshiba TCD1304AP detector, installed, with 200 – 850 nm variable longpass filter and UV4 quartz window: best for systems configured with XR-1 grating	FLAME-T
DET4-350-1000	Toshiba TCD1304AP detector, installed, with 350 – 1000 nm variable longpass filter; best for VIS systems configured with Grating #2 or #3	FLAME-T
DET4-UV	Toshiba TCD1304AP detector, installed, with UV4 quartz window; best for systems configured for <360 nm	FLAME-T
DET4-VIS	Toshiba TCD1304AP detector, installed, with VIS BK7 quartz window: best for systems configured for >400 nm	FLAME-T

Technical Specifications

Specification	FLAME-S	FLAME-T
Optical and Spectroscopic		
Integration Time	1 ms – 65 seconds	3.8 ms to 10 seconds
Dynamic Range for single acquisition ¹	1300:1	
Dynamic Range of system ²	2×10^8	3.4×10^6
Signal-to-Noise (single acquisition)	250:1	300:1
Resolution (FWHM)	0.1 – 10.0 nm (configuration dependent)	
Stray Light	<0.05% at 600 nm <0.10% at 435 nm	
Scan rate (max) ³	400 Hz	260 Hz
Spectrometer Channels	One	
Thermal Stability	0.02 nm/°C for 650 nm range, 0.06 pixels/°C	
Triggering	4 modes	
Triggering Jitter	21 nanoseconds	
Detector		
Type	Sony ILX511B CCD	Toshiba TCD1304AP CCD
Detector range	190-1100 nm	
Pixels	2048 pixels	3648 pixels
Pixel size	14 μm x 200 μm	8 μm x 200 μm
Electronic shutter	No	Yes
Pixel well depth	~62,500 electrons	~100,000 electrons
Readout noise (single dark spectrum)	50 counts RMS, 300 counts peak-to-peak	

6: Technical Specifications

Specification	FLAME-S	FLAME-T
Corrected linearity	>99.8%	
Filters (optional)	2 nd and 3 rd order rejection, long pass	
Electrical		
Power requirement (spectrometer functions)	250 mA at +5 VDC	
Supply voltage	4.75 – 5.25 V	
Power-up time	~2s	
Connectors	Micro-USB and JAE DD4 (DD4RA40JA1) 40-pin connector	
Micro-USB Absolute Maximum Ratings: V _{CC}	+ 5.5 VDC	
DD4 Absolute Maximum Ratings: V _{CC} (Pin 40) Voltage on any pin (other than input power)	+ 5.5 VDC +4VDC	
Interface: USB RS-232	USB 2.0, 480 Mbps 2-wire RS-232	
Mechanical		
Spectrometer Design	Asymmetric crossed Czerny-Turner	
Input Fiber Connector	SMA 905 or FC	
Gratings	15 different gratings. See Chapter 5: How the Flame Spectrometer Works for more information.	
Entrance Slit	5, 10, 25, 50, 100, or 200 μm slits. (Slits are optional. In the absence of a slit, the fiber acts as the entrance slit.)	
Physical Dimensions	88.9 mm x 63.5 mm x 31.9 mm	
Weight	265 g	
Environmental		
Temperature: Storage Operation	-30° to +70° C 0 to 50° C	

Specification	FLAME-S	FLAME-T
Humidity	0% - 90% noncondensing	
Compliance⁴		
Electrical	CE, FCC	
Material	RoHS	
Shock	IEC 60068-2-64	
Vibration	IEC 60068-2-31	
Manufacturing	ISO:9001	
<p>¹ Dynamic range for a single acquisition is a measure of the ratio of full signal to noise.</p>		
<p>² Dynamic range of the system is the range of the detectable light level and can be thought of as the maximum detectable light level at the minimum integration time divided by the minimum detectable light level at the maximum integration time.</p>		
<p>³ Scan rate is dependent on the operating computer and not the spectrometer. These figures assume a non real-time operating system.</p>		
<p>⁴ Contact info@oceanoptics.com to obtain copies of certifications</p>		

Mechanical Diagram

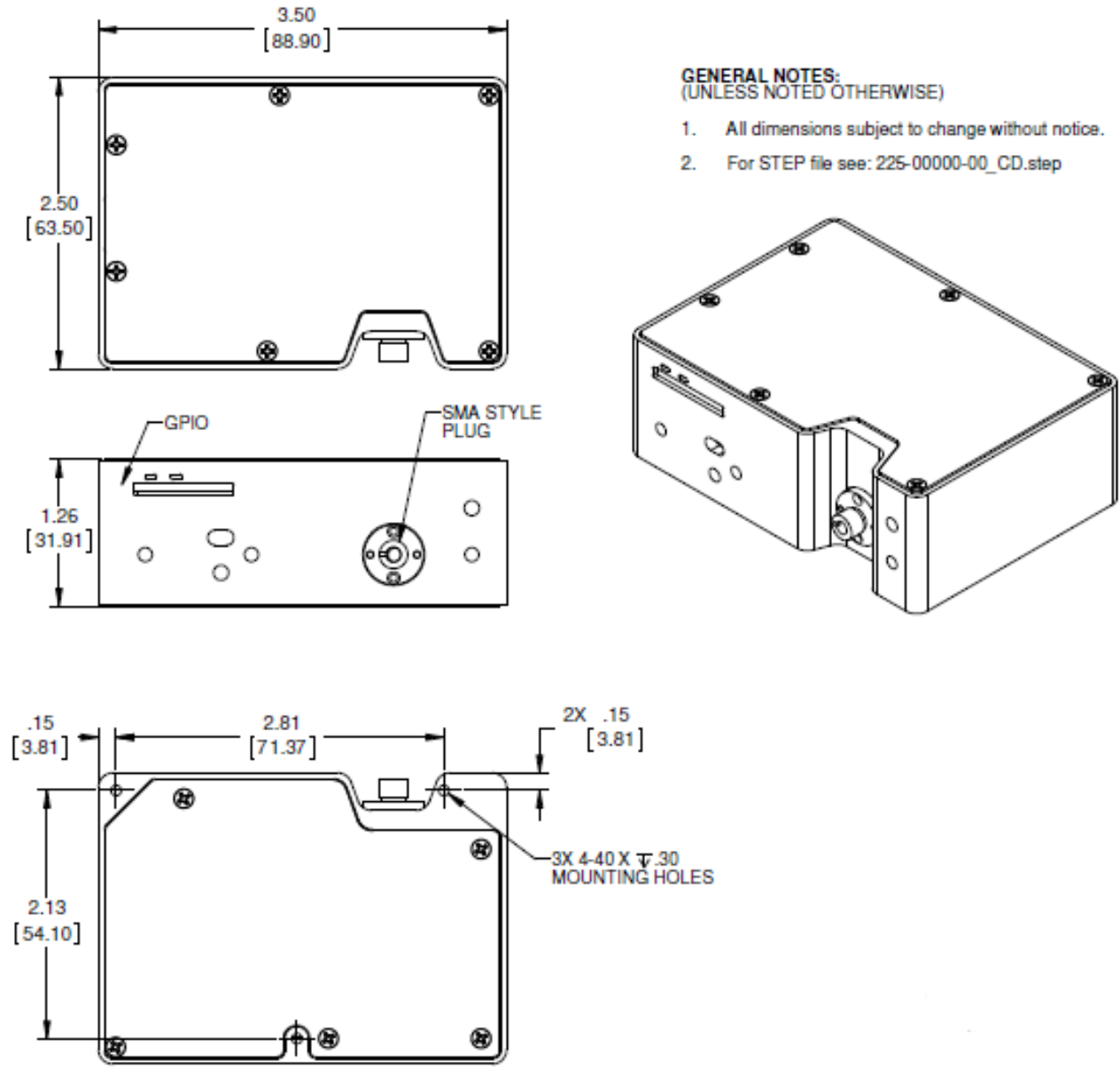

GENERAL NOTES:
(UNLESS NOTED OTHERWISE)

1. All dimensions subject to change without notice.
2. For STEP file see: 225-00000-00_CD.step

Figure 1: Flame Outer Dimensions

Electrical Pinout

The Flame features a 40-pin Accessory Connector, located on the front of the unit as shown:



Location of Flame Accessory Connector

DD4 Accessory Connector Pinout Diagram

When facing the 40-pin Accessory Connector on the front of the vertical wall of the Flame, pin number 1 is on the right.

Listed below is the pin description for the Flame Accessory Connector located on the front vertical wall of the unit. The Flame will include a JAE DD4 receptacle, part number DD4RA40JA1. Most accessories that plug into the Flame will include a JAE DD4 plug, part number DD4PA40MA1. There is also a vertical connector, JAE part number DD4BA40WA1.

Pin #	Function	Description
1	Ground	Ground
2	Trigger	The TTL trigger signal.
3	Continuous Strobe	TTL output signal used to pulse a strobe that is divided down from the Master Clock signal.
4	Single Strobe	TTL output pulse used as a strobe signal, which has a programmable delay relative to the beginning of the spectrometer integration period.
5	Lamp Enable	A TTL signal that is driven Active HIGH when the Lamp Enable command is sent to the Flame.

6: Technical Specifications

Pin #	Function	Description
6	GPIO 0	General Purpose Software Programmable Digital Inputs/Output*
7	GPIO 1	General Purpose Software Programmable Digital Inputs/Output*
8	GPIO 2	General Purpose Software Programmable Digital Inputs/Output*
9	GPIO 3	General Purpose Software Programmable Digital Inputs/Output*
10	Ground	General Purpose Software Programmable Digital Inputs/Output*
11	GPIO 4	General Purpose Software Programmable Digital Inputs/Output*
12	GPIO 5	General Purpose Software Programmable Digital Inputs/Output*
13	GPIO 6	General Purpose Software Programmable Digital Inputs/Output*
14	GPIO 7	General Purpose Software Programmable Digital Inputs/Output*
15	Ground	Ground
16	SPI Master Clock	Master clock (not used). See SPI below.
17	SPI Master MOSI	The SPI Master Out Slave In (MOSI) signal for communications to other SPI peripherals (not used). See SPI below.
18	SPI Master CS	TTL output signal used to pulse a strobe that is divided down from the Master Clock signal (not used). See SPI below.
19	SPI Master MISO	The SPI Master In Slave Out (MISO) signal for communications to other SPI peripherals (not used). See SPI below.
20	Ground	Ground
21	I ² C Master Clock	I ² C Master Clock (not used). See I2C below.
22	I ² C Master Data	I ² C Master Data (not used). See I2C below.
23	Ground	Ground
24	RS232 TX	RS232 Transmit signal – for communication with PC connect
25	RS232 RX	RS232 Receive signal – for communication with PC connect
26	Reserved	Reserved
27	Reserved	Reserved
28	Reset	Reset

Pin #	Function	Description
29	Reserved	Reserved
30	Reserved	Reserved
31	Reserved	Reserved
32	Reserved	Reserved
33	Reserved	Reserved
34	Reserved	Reserved
35	Reserved	Reserved
36	Reserved	Reserved
37	Reserved	Reserved
38	5V Out	The input power pin from the Flame.
39	Ground	Ground
40	5V In	The input power pin to the Flame. This is the input power pin to the Flame. Additionally when operating via a Universal Serial Bus (USB) this is the USB power connection (+5V) which can be used to power other peripherals (Care must be taken to insure that the peripheral complies with USB Specifications). The entire assembly should not draw more than 500 mA. NOTE: Do <u>not</u> connect both USB power and Auxiliary power (as an input) at the same time.
*See the Caution below.		

Caution

Do not connect the GPIO pins to 5V. The GPIOs are not 5V tolerant and will be damaged if connected to 5V. The maximum voltage is 4V.

SPI

The Flame has the ability to function as a SPI master through the SPI port, which comprises the SPI Master Clock, SPI Master MOSI, SPI Master CS, and SPI Master MISO pins. To send messages over the SPI port, use the *General SPI Input/Output* message. The Flame does not send or receive any SPI data without direction from its host PC.

Because SPI is a full-duplex transaction, the *General SPI Input/Output* message both reads and writes at the same time. For instance, a four byte write will return four bytes of dummy read data, and a four byte read requires four bytes of dummy write data:

- MOSI data is established just prior to the rising edge of the SPI clock

- MISO data is sampled just after a falling edge of the SPI clock.

I2C

The Flame has the ability to function as an I2C master through the I2C port, which comprises the I2C-SDA, and I2C-SCL pins. To send messages over the I2C port, use the General I2C Write and General I2C Read messages. Note that the Flame does not send or receive any I2C data without direction from its host PC. The I2C lines are pulled up internally to 3.3V by 2K resistors.

CCD Overview

CCD Detector

The detector used for the Flame is a charge transfer device (CCD) that has a fixed well depth (capacitor) associated with each photodetector (pixel).

Charge transfer, reset and readout initiation begin with the integration time clock going HIGH. At this point, the remaining charge in the detector wells is transferred to a shift register for serial transfer. This process is how the array is read.

The reset function recharges the photodetector wells to their full potential and allows for nearly continuous integration of the light energy during the integration time, while the data is read out through serial shift registers. At the end of an integration period, the process is repeated.

When a well is fully depleted by leakage through the back-biased photodetector, the detector is considered saturated and provides the maximum output level. The CCD is a depletion device and thus the output signal is inversely proportional to the input photons. The electronics in the Flame invert and amplify this electrical signal.

CCD Well Depth

We strive for a large signal-to-noise (S:N) in optical measurements so that small signal variations can be observed and a large dynamic range is available. The S:N in photon noise-limited systems is defined and measured as the square root of the number of photons it takes to fill a well to saturation. In the Flame, the well depth of the CCD pixels is about 160,000 photons, providing a S:N of 400:1 (S:N can also be measured as the saturation voltage divided by near-saturation RMS noise). There is also a fixed readout noise component to all samples. The result is a system with a S:N of ~275:1.

There are two ways to achieve a large S:N (e.g., 6000:1) in CCD detectors where photon noise is predominant.

1. Use a large-well device that integrates to saturation over a long period of time until the photon noise is averaged out by the root of n multiples of a defined short Δt .
2. Use a small-well device that integrates to saturation at one short Δt and then signal average mathematically n times.

Theoretically, both approaches achieve the same results, though there are large differences in actual operation. Traditional spectroscopic instruments use large-well devices and 16-bit ADCs to achieve the defined S:N. The Flame uses a small-well device and utilizes signal averaging to achieve the same S:N. A brief comparison of large and small-well devices is shown in the table below.

Well Depth Comparison

Large-well CCDs	Small-well CCDs
Low photon noise	Medium photon noise that can be averaged out
Low optical sensitivity	High optical sensitivity
High power consumption	Low power consumption
>10 MHz operating speeds	Moderate operating speeds (~2 MHz)

Signal Averaging

Signal averaging is an important tool in the measurement of spectral structures. It increases the S:N and the amplitude resolution of a set of samples. The types of signal averaging available in our software are time-based and spatial-based.

When using the time-base type of signal averaging, the S:N increases by the square root of the number of samples. Signal averaging by summing is used when spectra are fairly stable over the sample period. Thus, a S:N of 2500:1 is readily achieved by averaging 100 spectra.

Spatial averaging or pixel boxcar averaging can be used to improve S:N when observed spectral structures are broad. The traditional boxcar algorithm averages n pixel values on each side of a given pixel.

Time-based and spatial-based algorithms are not correlated, so therefore the improvement in S:N is the product of the two processes.

In review, large-well devices are far less sensitive than small-well devices and thus, require a longer integration time for the same output. Large-well devices achieve a good S:N because they integrate out photon noise. Small-well devices must use mathematical signal averaging to achieve the same results as large-well devices, but small-well devices can achieve the results in the *same period of time*. This kind of signal averaging was not possible in the past because analog-to-digital converters and computers were too slow.

Large-well devices consume large amounts of power, resulting in the need to build thermoelectric coolers to control temperature and reduce electronic noise. Then, even more power is required for the temperature stabilization hardware. But small-well devices only need to use signal averaging to achieve the same results as large-well devices, and have the advantages of remaining cool and less noisy.

Internal Operation

Pixel Definition

A series of pixels in the beginning of the scan have been covered with an opaque material to compensate for thermal induced drift of the baseline signal. As the Flame warms up, the baseline signal will shift slowly downward a few counts depending on the external environment. The baseline signal is set at the time of manufacture. If the baseline signal is manually adjusted, it should be left high enough to allow for system drift. The following is a description of all of the pixels, both as they exist on the hardware device and as they are actually read from the device via USB:

Pixels on the FLAME-S

Pixel	Description
0–11	Not usable
12–29	Optical black pixels
30–31	Not usable
32–2079	Optical active pixels
2080–2085	Not usable

Pixels on the FLAME-T

Pixel	Description
1–5	Not usable
6–18	Optical black pixels
19–21	Transition pixels
22–3669	Optical active pixels
3670–3681	Not usable

Pixels Read from the Flame-S via USB

Pixel	Description
0–17	Optical black pixels
18–19	Not usable
20-2047	Optical active pixels

It is important to note that the Flame-S only digitizes the first 2048 pixels. For Flame-T, Ocean Optics software displays 3648 pixels starting at pixel 1 above. In RS232 interface mode, the USB4000 transmits out the first 3670 pixels.

CCD Detector Reset Operation

At the start of each integration period, the detector transfers the signal from each pixel to the readout registers and resets the pixels. The total amount of time required to perform this operation is $\sim 8 - 9 \mu\text{s}$. The user needs to account for this time delay when the pixels are optically inactive, especially in the external triggering modes.

Timing Signals

Strobe Signals

Single Strobe

The Single Strobe signal is a programmable TTL pulse that occurs at a user-determined time during each integration period. This pulse has a user-defined High Transition Delay and Low Transition Delay. The pulse width of the Single Strobe is the difference between these delays. It is only active if the Lamp Enable command is active.

Synchronization of external devices to the spectrometer's integration period is accomplished with this pulse. The Strobe Delay is specified by the Single Strobe High Transition Delay (SSHTD) and the Pulse Width is specified by the Single Strobe Low Transition Delay (SSLTD) minus the Single Strobe High Transition Delay ($PW = SSLTD - SSHTD$). Both values are programmable in 500ns increments for the range of 0 to 65,535 (32.7675ms).

The timing of the Single Strobe is based on the Start of Integration (SOI). SOI occurs on the rising edge of ϕ ROG which is used to reset the Sony ILX511 detector. In all trigger modes using an External Trigger, there is a fixed relationship between the trigger and the SOI. In the Normal mode and Software Trigger mode, the SOI still marks the beginning of the Single Strobe, but due to the nondeterministic timing of the software and computer operating system, this timing will change over time and is not periodic. That is, at a constant integration time, the Single Strobe will not be periodic, but it will indicate the start of the integration. The timing diagram for the Single Strobe in External Hardware Trigger mode is shown below:

The Trigger Delay (TD) is another user programmable delay which specifies the time in 500ns increments that the SOI will be delayed beyond the normal Start of Integration Delay (SOID).

An example calculation of the Single Strobe timing follows:

If the $TD = 1ms$, $SSHTD = 50ms$, and $SSLTD = 70ms$ then, the rising edge of the Single Strobe will occur approximately 51.82ms ($1ms + 50ms + 8.2\mu s$) after the External Trigger Input goes high and the Pulse Width will be 20ms ($70ms - 50ms$).

Continuous Strobe

The Continuous Strobe signal is a programmable frequency pulse-train with a 50% duty cycle. It is programmed by specifying the desired period whose range is 2 μs to 60s. This signal is continuous once enabled, but is not synchronized to the Start of Integration or External Trigger Input. The Continuous Strobe is only active if the Lamp Enable command is active.

Synchronizing Strobe Events

If the application requires more than one pulse per integration period, the user needs to insure the continuous strobe and integration period are synchronized. The integration time must be set so that an equal number of strobe events occurs during any given integration period.

External Triggering

The Flame Spectrometer has several ways of acquiring data. In the Normal/Free-Run mode, the spectrometer is “free running.” That is, the spectrometer is continuously scanning, acquiring, and making data available to your computer, according to parameters set in the software. In this mode, there is no way to synchronize the scanning, acquisition, and transfer of data with an external event. However, trigger pulses for synchronizing an external event with the spectrometer are available.

Each trigger mode involves connecting an external triggering device to the spectrometer and then applying an external trigger to the spectrometer before the software receives the data. The length of the integration time and the source for the integration clock depend upon the mode chosen. All other acquisition parameters are set in the software.

You can trigger the Flame using a variety of External Triggering options through the 40-pin Accessory Connector on the spectrometer. See the External Triggering Options document located at http://oceanoptics.com/wp-content/uploads/External-Triggering-Options_Firmware3.0andAbove.pdf. The triggering document contains further instructions for configuring External Triggering options for the Flame.

Triggering Modes

The Flame supports three triggering modes, (plus Normal mode), which are set with the Trigger Mode command. Detailed information of each triggering mode follows. Also refer to the External Triggering Options document located on our website at http://oceanoptics.com/wp-content/uploads/External-Triggering-Options_Firmware3.0andAbove.pdf. The following paragraphs describe these modes.

Normal

In the Normal (Free-run) mode, the spectrometer will acquire a spectrum based on the integration period specified through the software interface. This data is made available for reading as soon as all the data is stored. The spectrometer will then immediately try to acquire two additional spectra even if none have been requested. If a new spectrum request has come from the user, during either the second or third integration cycle then the appropriate spectrum will be available to the user. If a second spectrum has not been requested then the spectrometer will not save the second or third spectrum and will go into an idle mode waiting for a new spectrum request from the user. In this scenario, a new acquisition begins when a new spectrum is requested. No further spectra are acquired until the original spectrum is read by the user.

External Synchronous Trigger Mode

In the External Synchronous Trigger mode, two external triggers are required to complete a data acquisition. The first rising edge starts the integration period and the second rising edge stops the integration and starts the next. Thus the integration time is the period between the two external trigger pulses. After the integration period, the spectrum is retrieved and available

to the user. As in normal mode, no further spectra are acquired until the original spectrum is read by the user.

External Hardware Level Trigger Mode

In the External Hardware Level Trigger mode, a rising edge detected by the spectrometer from the External Trigger input starts the integration period specified through the software interface. After the integration period, the spectrum is retrieved and is ready to be read by the user. As long as the trigger level remains active in a logic one state, back-to-back acquisitions can occur, as in the Normal mode, until the trigger transitions to an inactive level. As in normal mode, no further spectra are acquired until the original spectrum is read by the user.

External Hardware Edge Trigger Mode

In the External Hardware Edge Trigger mode, a rising edge detected by the spectrometer from the External Trigger input starts the integration period specified through the software interface. After the integration period, the spectrum is retrieved and is ready to be read by the user. If another trigger is sent a new integration cycle will begin. If a spectrum request is not received before the integration cycle has ended then that data will be deleted and a new trigger and spectrum request is required. Only one acquisition will be performed for each External Trigger pulse, no matter what the pulse's duration is. No further spectra are acquired until the original spectrum is read by the user.

Flame -- Timetable for Hardware Edge Trigger Mode

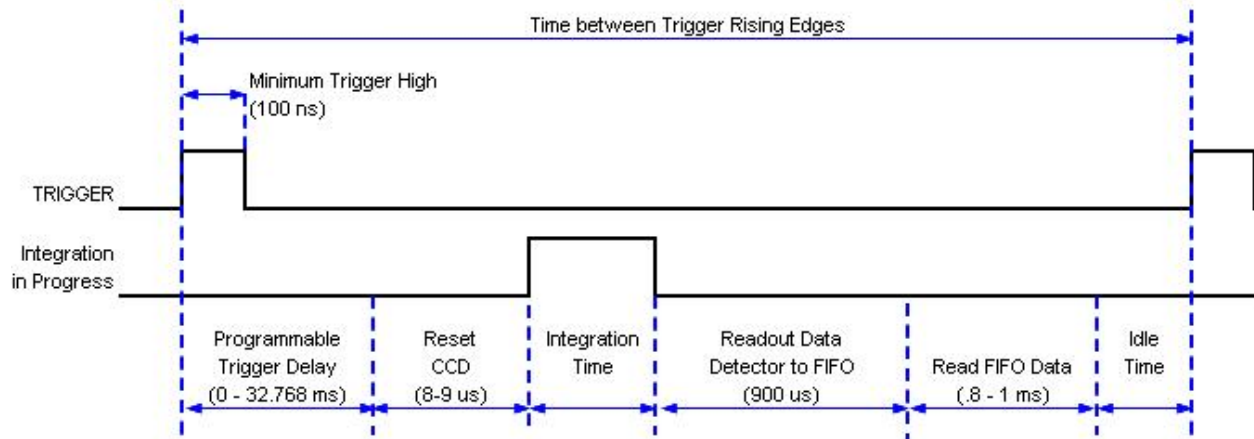

Additional Delay	0 us
Initialize CCD Binning	9,000 us
Integration time	1,000 us
Read Detector	900 us
Minimum Idle States	1,000 us
Min Trigger Cycle	2,909 us
Min Trigger Cycle	2,909 us
Max Trigger Rate	344 Hz

See [DD4 Accessory Connector Pinout](#) Diagram to locate the pins to set up triggering.

Chapter 7

Calibration

Overview

This chapter provides information for performing your own wavelength calibration and irradiance calibration.

An EEPROM flash memory chip in each Flame contains wavelength calibration coefficients, linearity coefficients, and a serial number unique to each individual spectrometer. The spectrometer operating software application reads these values directly from the spectrometer, enabling the ability to “hot-swap” spectrometers between computers without entering the spectrometer coefficients manually on each computer.

USB Programmer software is freely available from Ocean Optics: <http://oceanoptics.com/support/software-downloads/>. This software can be used to write calibration coefficients to the spectrometer and reload firmware if the spectrometer becomes corrupted.

Wavelength Calibration

This section describes how to calibrate the wavelength of your spectrometer. Though each spectrometer is calibrated before it leaves Ocean Optics, the wavelength for all spectrometers will drift slightly as a function of time and environmental conditions. Ocean Optics recommends periodically recalibrating the Flame.

About Wavelength Calibration

You are going to be solving the following equation, which shows that the relationship between pixel number and wavelength is a third-order polynomial:

$$\lambda_p = I + C_1 p + C_2 p^2 + C_3 p^3$$

Where:

λ = the wavelength of pixel p

I = the wavelength of pixel 0

C_1 = the first coefficient (nm/pixel)

C_2 = the second coefficient (nm/pixel²)

C_3 = the third coefficient (nm/pixel³)

You will be calculating the value for I and the three C s.

Calibrating the Spectrometer Wavelength

Preparing for Calibration

To recalibrate the wavelength of your spectrometer, you need the following components:

- A light source capable of producing spectral lines

Note

Ocean Optics' HG-1 Mercury-Argon lamp is ideal for recalibration. If you do not have an HG-1, you need a light source that produces several (at least 4-6) spectral lines in the wavelength region of your spectrometer.

- A Flame spectrometer
- An optical fiber (for spectrometers without a built-in slit, a 50- μ m fiber works best)
- A spreadsheet program (Excel or Quattro Pro, for example) or a calculator that performs third-order linear regressions

Note

If you are using Microsoft Excel, choose **Tools | Add-Ins** and check **AnalysisToolPak** and **AnalysisToolPak-VBA**.

Calibrating the Wavelength of the Spectrometer

► Procedure

Perform the steps below to calibrate the wavelength of the spectrometer:

1. Place the spectrometer operating software into Quick View (Scope) mode and take a spectrum of your light source. Adjust the integration time (or the A/D conversion frequency) until there are several peaks on the screen that are not off-scale.
2. Move the cursor to one of the peaks and position the cursor so that it is at the point of maximum intensity.
3. Record the pixel number that is displayed in the status bar or legend (located beneath the graph). Repeat this step for all of the peaks in your spectrum.
4. Use the spreadsheet program or calculator to create a table like the one shown in the following figure. In the first column, place the exact or true wavelength of the spectral lines that you used.

In the second column of this worksheet, place the observed pixel number. In the third column, calculate the pixel number squared, and in the fourth column, calculate the pixel number cubed.

Independent Variable	Dependent Variables			Values Computed from the Regression Output	
True Wavelength (nm)	Pixel #	Pixel # ²	Pixel # ³	Predicted Wavelength	Difference
253.65	175	30625	5359375	253.56	0.09
296.73	296	87616	25934336	296.72	0.01
302.15	312	97344	30371328	302.40	-0.25
313.16	342	116964	40001688	313.02	0.13
334.15	402	161604	64964808	334.19	-0.05
365.02	490	240100	117649000	365.05	-0.04
404.66	604	364816	220348864	404.67	-0.01
407.78	613	375769	230346397	407.78	0.00
435.84	694	481636	334255384	435.65	0.19
546.07	1022	1044484	1067462648	546.13	-0.06
576.96	1116	1245456	1389928896	577.05	-0.09
579.07	1122	1258884	1412467848	579.01	0.06
696.54	1491	2223081	3314613771	696.70	-0.15
706.72	1523	2319529	3532642667	706.62	0.10
727.29	1590	2528100	4019679000	727.24	0.06
738.40	1627	2647129	4306878883	738.53	-0.13
751.47	1669	2785561	4649101309	751.27	0.19

- Use the spreadsheet or calculator to calculate the wavelength calibration coefficients. In the spreadsheet program, find the functions to perform linear regressions.
 - If using Quattro Pro, look under **Tools | Advanced Math**
 - If using Excel, look under **Analysis ToolPak**
- Select the true wavelength as the dependent variable (Y). Select the pixel number, pixel number squared, and the pixel number cubed as the independent variables (X). After executing the regression, you will obtain an output similar to the one shown below. Numbers of importance are noted.

Regression Statistics

Multiple R 0.999999831
 R Square 0.999999663 ← R Squared
 Adjusted R Square 0.999999607
 Standard Error 0.125540214
 Observations 22

Intercept

	<u>Coefficients</u>	<u>Standard Error</u>	
Intercept	190.473993	0.369047536	← First coefficient
X Variable 1	0.36263983	0.001684745	

X Variable 2-1.174416E-05	8.35279E-07	
X Variable 3-2.523787E-09	2.656608E-10	Second coefficient
Third coefficient		

- Record the Intercept, as well as the First, Second, and Third Coefficients. Additionally, look at the value for R squared. It should be very close to 1. If not, you have most likely assigned one of your wavelengths incorrectly.

Keep these values at hand.

Saving the New Calibration Coefficients: USB Mode

Ocean Optics programs wavelength calibration coefficients unique to each Flame onto an EEPROM memory chip in the Flame.

You can overwrite old calibration coefficients on the EEPROM if you are using the Flame via the USB port.

► **Procedure**

To save wavelength calibration coefficients using the USB mode, perform the following steps:

- Ensure that the Flame is connected to the computer and that you have closed all other applications.
- Point your browser to <http://www.oceanoptics.com/technical/softwaredownloads.asp> and scroll down to **Microcode**. Select **USB EEPROM Programmer**.
- Save the setup file to your computer.
- Run the **Setup.exe** file to install the software. The **Welcome** screen appears.
- Click the **Next** button. The **Destination Location** screen appears.
- Accept the default installation location, or click the **Browse** button to specify a directory. Then, click the **Next** button. The **Program Manager Group** screen appears.
- Click the **Next** button. The **Start Installation** screen appears.
- Click the **Next** button to begin the installation. Once the installation finishes, the **Installation Complete** screen appears.
- Click the **Finish** button and reboot the computer when prompted.
- Navigate to the **USB EEPROM Programmer** from the Start menu and run the software.
- Click on the desired Flame device displayed in the left pane of the **USB Programmer** screen.
- Double-click on each of the calibration coefficients displayed in the right pane of the USB Programmer screen and enter the new values acquired in Steps 5 and 6 of the [Calibrating the Wavelength of the Spectrometer](#) section in this appendix.
- Repeat Step 12 for all of the new values.

14. Click on the **Save All Values** button to save the information, and then **Exit** the USB Programmer software.

The new wavelength calibration coefficients are now loaded onto the EEPROM memory chip on the Flame.

Irradiance Calibrations

Irradiance calibrations and relative irradiance calibrations are about quantifying the spectra, by translating the signal (incident number of photons) to a calibration. This can be either absolute (an atomic emission light source of known output power) or relative (corrected for instrument response function but not absolute units). It can be considered a measurement technique and is used widely in remote sensing, light metrology and anywhere where you wish to characterize the incident light source. Irradiance calibrations are not required for many techniques because these measure the relative signal changes with respect to the sample and not the light source.

You can find out more about irradiance calibration techniques at

<http://oceanoptics.com/measurementtechnique/irradiance/>.

OceanView has wizards that will step you through absolute irradiance and relative calibrations and more information on these is located in the OceanView manual (see [Product-Related Documentation](#)).

Firmware and Advanced Communications

FLAME-S Firmware

The Flame is a microcontroller-based Miniature Fiber Optic Spectrometer that can communicate via the Universal Serial Bus or RS-232. This section contains the necessary command information for controlling the Flame via the USB interface command. This information is mainly relevant to those who don't wish to use Ocean Optics OmniDriver or SeaBreeze device drivers, or to those who wish to communicate via RS-232.

Hardware Description

The Flame utilizes a Cypress CY7C68013 microcontroller that has a high speed 8051 combined with an USB2.0 ASIC. Program code and data coefficients are stored in external E²PROM that are loaded at boot-up via the I²C bus. The microcontroller has 16K of internal SRAM and 64K of external SRAM. Maximum throughput for spectral data is achieved when data flows directly from the external FIFO's directly across the USB bus. In this mode the 8051 does not have access to the data and thus no manipulation of the data is possible.

USB Information

Ocean Optics Vendor ID number is 0x2457 and the Product ID is 0x101E.

Instruction Set

Command Syntax

The list of the commands is shown in the following table followed by a detailed description of each command. The length of the data depends on the command. All commands are sent to the Flame through End Point 1 Out (EP1). All spectra data is acquired through End Point 2 In and all other queries are retrieved through End Point 1 In (EP1). The endpoints enabled and their order is:

Flame-S Endpoints

Pipe #	Description	Type	Hi Speed Size (Bytes)	Full Speed Size (Bytes)	Endpoint Address
0	End Point 1 Out	Bulk	512	64	0x01
1	End Point 2 In	Bulk	512	64	0x82
2	End Point 6 In	Bulk	512	64	0x86
3	End Point 1 In	Bulk	512	64	0x81

USB Command Summary

EP1 Command Byte Value	Description
0x01	Initialize Flame
0x02	Set Integration Time
0x03	Set Strobe Enable Status
0x04	Set Shutdown Mode
0x05	Query Information
0x06	Write Information
0x09	Request Spectra
0x0A	Set Trigger Mode
0x0B	Query number of Plug-in Accessories Present
0x0C	Query Plug-in Identifiers
0x0D	Detect Plug-ins
0x12	LED Status
0x60	General I ² C Read

EP1 Command Byte Value	Description
0x61	General I ² C Write
0x62	General SPI I/O
0x6A	Write Register Information
0x6B	Read Register Information
0x6C	Read PCB Temperature
0x6D	Read Irradiance Calibration Factors
0x6E	Write Irradiance Calibration Factors
0xFE	Query Information

USB Command Descriptions

A detailed description of all Flame commands follows. While all commands are sent to EP1 over the USB port, the byte sequence is command dependent. The general format is the first byte is the command value and the additional bytes are command specific values.

Byte 0	Byte 1	Byte 2	...	Byte n-1
Command Byte	Command Specific	Command Specific	...	Command Specific

Initialize Flame

Initializes certain parameters on the Flame and sets internal variables based on the USB communication speed the device is operating at. This command should be called at the start of every session; however, if the user does not call it, it will be executed on the first Request Scan command. The default values are set as follows:

Parameter	Default Value
Trigger Mode	0 – Normal Trigger

Byte Format

Byte 0
0x01

Set Integration Time

Sets the Flame integration time in microseconds. The value is a 32-bit value whose acceptable range is 1,000 μ s – 65,535,000 μ s. If the value is outside this range the value is unchanged. For integration times less than 655,000 μ s, the integration counter has a resolution of 10 μ s. For integration times greater than this the integration counter has a resolution of 1ms.

Byte Format

Byte 0	Byte 1	Byte 2	Byte 3	Byte 4
0x02	LSW-LSB	LSW-MSB	MSW-LSB	MSW-MSB

MSW & LSW: Most/Least Significant Word

MSB & LSB: Most/Least Significant Byte

Set Strobe Enable Status

Sets the Flame Lamp Enable line (J2 pin 4) as follows. The Single Strobe and Continuous Strobe signals are enabled/disabled by this Lamp Enable Signal.

Data Byte = 0 → Lamp Enable Low/Off
Data Byte = 1 → Lamp Enable HIGH/On

Byte Format

Byte 0	Byte 1	Byte 2
0x03	Data byte LSB	Data Byte MSB

Set Shutdown Mode

Sets the Flame shutdown mode. When shutdown, the internal FX2 microcontroller is continuously running however all other functionality is disabled. In this power down mode the current consumption is reduced to 250mA (operating current for the FX2 microcontroller). When shutdown is active (active low), the external 5V signal (V5_Switched pin 3) is disabled in addition to all other signals except I²C lines.

Data Byte = 0 → Shutdown everything but the FX2
Data Byte = !0 → Power up entire Spectrometer

Byte Format

Byte 0	Byte 1	Byte 2
0x04	Data byte LSB	Data Byte MSB

Query Information

Queries any of the 20 stored spectrometer configuration variables. The Query command is sent to End Point 1 Out and the data is retrieved through End Point 1 In. When using Query Information to read EEPROM slots, data is returned as ASCII text. However, everything after the first byte that is equal to numerical zero will be returned as garbage and should be ignored.

The 20 configuration variables are indexed as follows:

Configuration Index - Description
0 – Serial Number
1 – 0 th order Wavelength Calibration Coefficient
2 – 1 st order Wavelength Calibration Coefficient
3 – 2 nd order Wavelength Calibration Coefficient
4 – 3 rd order Wavelength Calibration Coefficient
5 – Stray light constant
6 – 0 th order non-linearity correction coefficient
7 – 1 st order non-linearity correction coefficient
8 – 2 nd order non-linearity correction coefficient
9 – 3 rd order non-linearity correction coefficient
10 – 4 th order non-linearity correction coefficient
11 – 5 th order non-linearity correction coefficient
12 – 6 th order non-linearity correction coefficient
13 – 7 th order non-linearity correction coefficient
14 – Polynomial order of non-linearity calibration
15 – Optical bench configuration: gg fff sss
gg – Grating #, fff – filter wavelength, sss – slit size
16 – Flame configuration: AWL V
A – Array coating Mfg, W – Array wavelength (VIS, UV, OFLV), L – L2 lens installed, V – CPLD Version
17 – Reserved
18 – Reserved
19 – Reserved

Byte Format

Byte 0	Byte 1
0x05	Configuration Index

Return Format (EP1)

The data is returned in ASCII format and read in by the host through End Point 1.

Byte 0	Byte 1	Byte 2	Byte 3	...	Byte 16
0x05	Configuration Index	ASCII byte 0	ASCII byte 1	...	ASCII byte 14

Write Information

Writes any of the 19 stored spectrometer configuration variables to EEPROM. The 19 configuration variables are indexed as described in the Query Information. The information to be written is transferred as ASCII information.

Byte Format

Byte 0	Byte 1	Byte 2	Byte 3	...	Byte 16
0x06	Configuration Index	ASCII byte 0	ASCII byte 1	...	ASCII byte 14

Request Spectra

Initiates spectra acquisition. The Flame will acquire a complete spectrum (2048 pixel values). The data is returned in bulk transfer mode through EP2. The table below provides the pixel order overview for the 2 different speeds. The pixel values are decoded as described below.

Byte Format

Byte 0
0x09

Return Format

The format for the returned spectral data is dependent upon the USB communication. The format for both High Speed (480 Mbps) and Full Speed (12Mbps) is shown below. All pixel values are 16 bit values which are organized in LSB | MSB order. There is an additional packet containing one value that is used as a flag to insure proper synchronization between the PC and Flame.

USB High Speed (480Mbps) Packet Format

The data is read from EP2In. The packet format is described below.

Packet #	End Point	# Bytes	Pixels
0	EP2In	512	0-255
1	EP2In	512	256-511
2	EP2In	512	512-767
3	EP2In	512	768-1023
4	EP2In	512	1024-1279
5	EP2In	512	1280-1535
...	EP2In	512	
7	EP2In	512	1792-2048
8	EP2In	1	Sync Packet

The format for the first packet is as follows (all other packets except the synch packet has a similar format except the pixel numbers are incremented by 256 pixels for each packet).

Packet 0

Byte 0	Byte 1	Byte 2	Byte 3
Pixel 0 LSB	Pixel 0 MSB	Pixel 1 LSB	Pixel 1 MSB

...

		Byte 510	Byte 511
		Pixel 255 LSB	Pixel 255 MSB

Packet 15 – Synchronization Packet (1 byte)

Byte 0
0x69

USB Full Speed (12Mbps) Packet Format

In this mode all data is read from EP2In. The pixel and packet format is shown below.

Packet #	End Point	# Bytes	Pixels
0	EP2In	64	0-31
1	EP2In	64	32-63
2	EP2In	64	64-95
...	EP2In	64	
63	EP2In	64	2016-2047
64	EP2In	1	Sync Packet

Packet 0

Byte 0	Byte 1	Byte 2	Byte 3
Pixel 0 LSB	Pixel 0 MSB	Pixel 1 LSB	Pixel 2 MSB

...

		Byte 62	Byte 63
		Pixel 31 LSB	Pixel 31 MSB

Packet 64 – Synchronization Packet (1 byte)

Byte 0
0x69

Autonulling

Slot 0x11 (17) contains autonulling information that has a scaling term used to adjust the magnitude of the entire spectrum. This can be read out by sending bytes 0x05 11 to the low-speed out endpoint (0x01) and then reading out 17 bytes from the low-speed in endpoint (0x81). The bytes of use are Byte offset 6 and 7. The 17 bytes will be formatted as follows:

0x05 11 XX XX XX XX SS SS XX XX XX XX XX XX XX XX

Where:

XX = reserved bytes (most are either unused or are only used internally to the device)

SS = saturation level of the device as two bytes (LSB followed by MSB).

These need to be assembled into a single 16-bit value. Any time that a spectrum is read from the spectrometer, each pixel's intensity value should be multiplied by (65535.0/saturation_level) to set the scale appropriately.

The contents of slot 0x11 are set at the factory and should not be altered.

Set Trigger Mode

Sets the Flame Trigger mode to one of four states. If an unacceptable value is passed then the trigger state is unchanged (refer to the [External Triggering Options Instructions](#) for a description of the trigger modes).

Data Value = 0 → Normal (Free running) Mode
Data Value = 1 → External Hardware Level Trigger Mode
Data Value = 2 → External Synchronization Trigger Mode
Data Value = 3 → External Hardware Edge Trigger Mode

Byte Format

Byte 0	Byte 1	Byte 2
0x0A	Data Value LSB	Data Value MSB

Query Number of Plug-in Accessories

To query the number of preset plug-in accessories, use the Query Plug-in Identifiers command 0x0C (below), matching plug-in IDs to the known IDs.

Query Plug-in Identifiers

Queries the Plug-in accessories identifiers. This command returns 7 bytes with the last byte always being zero at this point. Each of the first 6 bytes correspond to Ocean Optics compatible devices which responded appropriately for I²C addresses 2 through 7 respectively. The I²C addresses are reserved for various categories of devices and the value for each category is shown below. I²C addresses 0-1 are reserved for loading program code from EEPROMS

Byte Format

Byte 0
0x0C

Return Format

The data is returned in Binary format and read in by the host through End Point 7.

Byte 0	Byte 1	...	Byte 5	Byte 6
Value @ I ² C address 2	Value @ I ² C address 3	...	Value @ I ² C address 7	0x00

Detect Plug-ins

Reads all of the plug-in accessories that are plugged into the I²C bus. No data values are returned.

Byte Format

Byte 0
0x0D

LED Status

Sets the Flame LEDs as follows.

Data Byte = 0 → LEDs Off
Data Byte = 1 → LEDs On

Byte Format

Byte 0	Byte 1
0x12	Data byte

General I2C Read

Performs a general purpose read on the I²C pins for interfacing to attached peripherals. The time to complete the command is determined by the amount of data transferred and the response time of the peripheral. The I²C bus runs at 400KHz. The maximum number of bytes that can be read is 61.

Command Byte Format

Byte 0	Byte 1	Byte 2
0x60	I ² C Address	Bytes to Read

Return Byte Format

Byte 0	Byte 1	Byte 2	Byte 3	...	Byte N+3
I ² C Results	I ² C Address	Bytes to Read	Data Byte 0	...	Data byte N

I ² C Result Value	Description
0	I ² C bus Idle
1	I ² C bus Sending Data
2	I ² C bus Receiving Data
3	I ² C bus Receiving first byte of string
5	I ² C bus in waiting for STOP condition
6	I ² C experienced Bit Error
7	I ² C experience a Not Acknowledge (NAK) Condition
8	I ² C experienced successful transfer
9	I ² C bus timed out

General I2C Write

Performs a general purpose write on the I²C pins for interfacing to attached peripherals. The time to complete the command is determined by the amount of data transferred and the response time of the peripheral. In all I2C communications, the first byte of the transaction consists of a 7 bit address and a read/write bit. The "address" that is passed as the second byte of the I2C write command is this 7 bit address, which will be shifted 1 bit left and appended with the R/W bit to form the first byte of the I2C write transaction. The I²C bus runs at 400KHz. The results codes are described above.

Command Byte Format

Byte 0	Byte 1	Byte 2	Byte 3	...	Byte N+3
0x61	I ² C Address	Bytes to Write	Data Byte 0	...	Data byte N

Return Byte Format

Byte 0
I ² C Results

General SPI Input/Output

Performs a general-purpose write and read on the SPI bus for interfacing to attached peripherals. The time to complete the command is determined by the amount of data transferred and the response time of the peripheral. Wait at least 10 ms after sending a Write command before reading the Return value. The SPI bus runs at ~125KHz Clock. The maximum number of bytes that can be written or read is 61. During this transfer the SPI Chip Select signal is driven to an active LOW TTL level. Data is transmitted out the MOSI (Master Out Slave In) line on the rising edge of the clock signal. Data is also latched in the from the MISO line on the falling edge of the clock signal.

Command Byte Format

Byte 0	Byte 1	Byte 2	Byte 3	...	Byte N+2
0x62	# of Bytes (N)	Write Byte 0	Write Byte 1	...	Write Byte N

Return Byte Format

Byte 0	Byte 1	Byte 2	...	Byte N+1
# of Bytes (N)	Read Byte 0	Read Byte 1	...	Read Byte N

Write Register Information

Most all of the controllable parameters for the Flame are accessible through this command (e.g., GPIO, strobe parameters, etc.). A complete list of these parameters with the associate register information is shown in the table below. Commands are written to End Point 1 Out typically with 4 bytes (some commands may require more data bytes). All data values are 16 bit values transferred in LSB | MSB order. This command requires 100us to complete; the calling program needs to delay for this length of time before issuing another command. In some instances, other commands will also write to these registers (i.e., integration time), in these cases the user has the options of setting the parameters through 2 different methods.

Byte Format

Byte 0	Byte 1	Byte 2	Byte 3
0x6A	Register Value	Data Byte LSB	Data Byte MSB

Register Address	Description	Default Value	Min Value	Max Value	Time Base
0x00*	Master Clock Counter Divisor	24	1	0xFFFF	48MHz
0x04	FPGA Firmware Version (Read Only)				
0x08	Continuous Strobe Timer Interval Divisor	48000	0	0xFFFF	Continuous Strobe Base Clock (see Register 0x0C)
0x0C	Continuous Strobe Base Clock Divisor	4800	0	0xFFFF	48MHz
0x0C	Continuous Strobe LSB Register	4800	0	0xFFFF	48MHz
0x10*	Integration Period Base Clock Divisor	480	0	0xFFFF	48MHz
0x10*	Integration Period LSB Register	480	0	0xFFFF	1KHz
0x14	Set base_clk or base_clkx2 0: base_clk 1: base_clkx2	0	0	1	N/A
0x18*	Integration Clock Timer Divisor	600	0	0xFFFF	Integration Period Base Clock (see Register 0x10)
0x18*	Integration Period MSB Register				
0x20	Reserved				
0x28	Hardware Trigger Delay – Number of Master Clock cycles to delay when in External Hardware Trigger mode before the start of the integration period	0	0	0xFFFF	
0x28	Hardware Trigger Delay – Delay the start of integration from the rising edge of the trigger in 500ns increments	0	0	0xFFFF	
0x2C&*	Trigger Mode 0 = Free Running 1 = External Hardware Level Trigger 1 = External Synchronization Trigger 3 = External Hardware Edge Trigger	0	0	4	N/A
0x30	Reserved				

8: Firmware and Advanced Communications

Register Address	Description	Default Value	Min Value	Max Value	Time Base
0x38	Single Strobe High Clock Transition Delay Count	1	0	0xFFFF	2MHz
0x3C	Single Strobe Low Clock Transition Delay Count	5	0	0xFFFF	2MHz
0x40	Lamp Enable	0	0	1	N/A
0x48	GPIO Mux Register 0: pin is GPIO pin 1: pin is alternate function	0	0	0x03FF	N/A
0x50	GPIO Output Enable 1: pin is output 0: pin is input	0	0	0x03FF	N/A
0x54	GPIO Data Register For Output: Write value of signal For Input: Read current GPIO state	0	0	0x03FF	N/A
0x58	Reserved				
0x5C	Offset Value	0	0	0xFFFF	N/A
0x60	Offset Control Bit 0 = Enable Auto-Nulling Bit 1 = Enable Auto-Nulling Saturation	0	0	0xFFFF	N/A
0x64	FPGA Programmed (Read Only)	0x5501	N/A	N/A	N/A
0x68	Maximum Saturation Level	0x55F0	0	0xFFFF	N/A

Notes:

* - User should not change these values because spectrometer performance can be affected. This information is included just for completeness

& - These values are controlled by other command interfaces to the Flame (i.e., Set integration time command).

Read Register Information

Read the values from any of the registers above. This command is sent to End Point 1 Out and the data is retrieved through End Point 1 In.

Byte Format

Byte 0	Byte 1
0x6B	Register Value

Return Format (EP1In)

Byte 0	Byte 1	Byte 2
Register Value	Value LSB	Value MSB

Read PCB Temperature

Read the Printed Circuit Board Temperature. The Flame contains a DS1721 temperature sensor chip which is mounted to the underside of the PCB. This command is sent to End Point 1 Out and the data is retrieved through End Point 1 In. The value returned is a signed 16-bit A/D conversion value, which is equated to temperature by:

$$\text{Temperature (}^{\circ}\text{C)} = .003906 * \text{ADC Value}$$

Byte Format

Byte 0
0x6C

Return Format (EP1In)

Byte 0	Byte 1	Byte 2
Read Result	ADC Value LSB	ADC Value MSB

If the operation was successful, the Read Result byte value will be 0x08. All other values indicate the operation was unsuccessful.

Read Irradiance Factors

Reads 60 bytes of data, which is utilized for Irradiance Calibration information from the desired EEPROM memory address.

Byte Format

Byte 0	Byte 1	Byte 2
0x6D	EEPROM Address LSB	EEPROM Address MSB

Return Byte Format

Byte 0	Byte 1	...	Byte 59
Byte 0	Byte 1	...	Byte 59

Write Irradiance Factors

Write 60 bytes of data, which is utilized for Irradiance Calibration information to the desired EEPROM memory address.

Byte Format

Byte 0	Byte 1	Byte 2	Byte 3	...	Byte 62
0x6E	EEPROM Address LSB	EEPROM Address MSB	Byte 0	...	Byte 59

Query Status

Returns a packet of information containing the current operating information. Packet structure is given below:

Byte Format

Byte 0
0xFE

Return Format

The data is returned in Binary format and read in by the host through End Point 1 In. The structure for the return information is as follows:

Byte	Description	Comments
0-1	Number of Pixels - WORD	LSB MSB order
2-5	Integration Time - WORD	Integration time in μs – LSW MSW. Within each word order is LSB MSB
6	Lamp Enable	0 – Signal LOW 1 – Signal HIGH

Byte	Description	Comments
7	Trigger Mode Value	
8	Spectral Acquisition Status	
9	Packets In Spectra	Returns the number of Packets in a Request Spectra Command.
10	Power Down Flag	0 – Circuit is powered down 1 – Circuit is powered up
11	Packet Count	Number of packets loaded into End Point Memory
12	Reserved	
13	Reserved	
14	USB Communications Speed	0 – Full Speed (12Mbps) 0x80 – High Speed (480 Mbps)
15	Reserved	

Flame –S Serial Port Interface Communications and Control Information

The Flame is a microcontroller-based Miniature Fiber Optic, which can communicate via the Universal Serial Bus or RS-232. This document contains the necessary command information for controlling the Flame via the RS-232 interface.

Hardware Description

The Flame utilizes a Cypress FX2 microcontroller, which has a high speed 8051, combined with an USB ASIC. Program code and data coefficients are stored in external E²PROM, which are loaded at boot-up via the I²C bus.

Instruction Set

Command Syntax

The list of the commands is shown in the following table along with the microcode version number they were introduced with. All commands consist of an ASCII character passed over the serial port, followed by some data. The length of the data depends on the command. The format for the data is either ASCII or binary (default). The ASCII mode is set with the “a” command and the binary mode with the “b” command. To insure accurate communications, all commands respond with an ACK (ASCII 6) for an acceptable command or a NAK (ASCII 21) for an unacceptable command (i.e. data value specified out of range).

In the ASCII data value mode, the Flame “echoes” the command back out the RS-232 port. In binary mode all data, except where noted, passes as 16-bit unsigned integers (WORDS) with the MSB followed by the LSB. By issuing the “v command” (Version number query), the data mode can be determined by viewing the response (ASCII or binary).

In a typical data acquisition session, the user sends commands to implement the desired spectral acquisition parameters (integration time, etc.). Then the user sends commands to acquire spectra (S command) with the previously set parameters. If necessary, the baud rate can be changed at the beginning of this sequence to speed up the data transmission process.

RS232 Command Summary

Letter	Description
A	Adds scans
B	Set Pixel Boxcar
C	
D	
E	
F	***Non functional but follows SAD500 command format***
G	Set Data Compression
H	***Non functional but follows SAD500 command format***
I	Sets integration time
J	Sets Lamp Enable Line
K	Changes baud rate
L	Clear Memory
M	Set Data Storage Mode
N	
O	
P	Partial Pixel Mode
Q	
R	
S	Starts spectral acquisition with previously set parameters
T	Sets trigger mode
U	
V	
W	Query scans in memory

Letter	Description
X	
Y	
Z	Read out Scan from memory
A	Set ASCII mode for data values
b	Set binary mode for data values
k	Sets Checksum mode
o	Oxygen (USB-LS-450) related commands
t	Temperature in hundredths of degrees C
u	Set Oxygen Calibration Coefficients
v	Provides microcode version #
x	Sets calibration coefficients
y	Sets 16-bit timer operation
?	Queries parameter values
+	Reads the plugged-in accessories
-	USB2000 Identifier

Command Descriptions

A detailed description of all Flame commands follows. The {} indicates a data value which is interpreted as either ASCII or binary (default). The default value indicates the value of the parameter upon power up.

Add Scans

Sets the number of discrete spectra to be summed together. Since the Flame has the ability to return 32 bit values, overflow of the raw 16 bit ADC value is not a concern.

Command Syntax:	A{DATA WORD}
Response:	ACK or NAK
Range:	1-5000
Default value:	1

Pixel Boxcar Width

Sets the number of pixels to be averaged together. A value of n specifies the averaging of n pixels to the right and n pixels to the left. This routine uses 32-bit integers so that intermediate overflow will not occur; however, the result is truncated to a 16-bit integer prior to transmission of the data. This math is performed just prior to each pixel value being transmitted out. Values greater than ~3 will exceed the idle time between values and slow down the overall transfer process.

Command Syntax:	B{DATA WORD}
Response:	ACK or NAK
Range:	0-15
Default value:	0

Set Data Compression

Specifies whether the data transmitted from the Flame should be compressed to speed data transfer rates.

Command Syntax:	G{DATA WORD}
Response:	ACK or NAK
Range:	0 – Compression off !0 – Compression on
Default value:	0

Integration Time (16 bit)

Sets the Flame's integration time, in milliseconds, to the value specified.

Command Syntax:	I{16 bit DATA WORD}
Response:	ACK or NAK
Range:	1 - 65000
Default value:	10

Integration Time (32 bit)

Sets the Flame's integration time, in microseconds, to the value specified.

Command Syntax:	i{32 bit DATA WORD}
Response:	ACK or NAK
Range:	1000 – 65,000,000
Default value:	10,000

Lamp Enable

Sets the Flame's Lamp Enable line to the value specified

Command Syntax:	J{DATA WORD}
Value:	0 = Light source/strobe off—Lamp Enable low 1 = Light source/strobe on—Lamp Enable high
Response:	ACK or NAK
Default value:	0

Baud Rate

Sets the Flame's baud rate.

Command Syntax:	K{DATA WORD}
Value:	0=2400 1=4800 2=9600 3=19200 4=38400 5=Not Supported 6=115,200
Response:	See below
Default value:	2

When changing baud rates, the following sequence must be followed:

1. Controlling program sends K with desired baud rate, communicating at the old baud rate
2. The Flame responds with ACK at old baud rate, otherwise it responds with NAK and the process is aborted
3. Controlling program waits longer than 50 milliseconds
4. Controlling program sends K, followed by the desired baud rate.

For example, to change the baud rate from 9600 to 115,200 in ASCII mode:

- At 9600 baud, send "K6<enter>"
- You will receive an ACK at 9600 baud

8: Firmware and Advanced Communications

- Send "K6<enter>" at 115200. (Note that the "K" is not echoed back, but the "6" is)
 - You will receive two ACK characters and the prompt at 115200 baud.
4. The Flame responds with ACK at new baud rate, otherwise it responds with NAK and old baud rate is used

 If a deviation occurs at any step, the previous baud rate is utilized.

Clear Memory

Clears the spectral data memory based on the valued specified. Clearing memory is immediate since only pointer values are reinitialized.

Caution: All stored spectra are lost when the Clear memory command is executed.

Command Syntax:	L{DATA WORD}
Value:	0= Clear spectral memory 1= Clear spectral memory
Response:	ACK or NAK
Default value:	N/A

Data Storage Mode

Sets the data storage mode for future spectral acquisitions.

Command Syntax:	M{DATA WORD}
Value:	0= Scans transmitted through the serial port 1= Scans stored in spectral memory and not transmitted
Response:	ACK or NAK
Default value:	0

Pixel Mode

Specifies which pixels are transmitted. While all pixels are acquired on every scan, this parameter determines which pixels will be transmitted out the serial port.

Command Syntax:	P{DATA WORD}	
Value:	<p>Description</p> <p>0 = all 2048 pixels</p> <p>1 = every nth pixel with no averaging</p> <p>2 = N/A</p> <p>3 = pixel x through y every n pixels</p> <p>4 = up to 10 randomly selected pixels between 0 and 2047 (denoted p1, p2, ... p10)</p>	<p>Example</p> <p>P 0 (spaces for clarity only)</p> <p>P 1<Enter></p> <p>N<Enter></p> <p>P 2 N/A</p> <p>P3<Enter></p> <p>x<Enter></p> <p>y<Enter></p> <p>n<Enter></p> <p>P 4<Enter></p> <p>n<Enter></p> <p>p1<Enter></p> <p>p2<Enter></p> <p>p3<Enter> ...</p> <p>p10<Enter></p>
Response:	ACK or NAK	
Default value:	0	

- ! Since most applications only require a subset of the spectrum, this mode can greatly reduce the amount of time required to transmit a spectrum while still providing all of the desired data. This mode is helpful when interfacing to PLCs or other processing equipment.

Spectral Acquisition

Acquires spectra with the current set of operating parameters. When executed, this command determines the amount of memory required. If sufficient memory does not exist, an ETX (ASCII 3) is immediately returned and no spectra are acquired. An STX (ASCII 2) is sent once the data is acquired and stored. If the Data Storage Mode value is 0, then the data is transmitted immediately.

Command Syntax:	S
Response:	<p>If successful, STX followed by data</p> <p>If unsuccessful, ETX</p>

The format of returned spectra includes a header to indicate scan number, channel number, pixel mode, etc. The format is as follows:

- WORD 0xFFFF – start of spectrum
- WORD Data size flag (0→Data is WORD's, 1→Data is DWORD's)
- WORD Number of Scans Accumulated
- WORD Integration time in milliseconds
- WORD FPGA Established Baseline value (MSW)
- WORD FPGA Established Baseline value (MSW)
- WORD pixel mode
- WORDS if pixel mode not 0, indicates parameters passed to the Pixel Mode command (P)
- (D)WORDS spectral data depending on Data size flag
- WORD 0xFFFD – end of spectrum

Trigger Mode

Sets the Flame's external trigger mode to the value specified.

Command Syntax:	T{DATA WORD}
Value:	0 = Normal (Free running) Mode 1 = Software Trigger Mode 2 = External Hardware Level Trigger Mode 3 = External Synchronization Trigger Mode 4 = External Hardware Edge Trigger Mode
Response:	ACK or NAK
Default value:	0

Set FPGA Register Value

Sets the appropriate register within the FPGA. The list of register setting is in the USB command set information. This command requires two data values, one to specify the register and the next to specify the value.

Command Syntax:	W{DATA WORD 1}{DATA WORD 2}
Value:	Data Word 1 – FPGA Register address Data Word 2 – FPGA Register Value
Response:	ACK or NAK
Default value:	N/A

ASCII Data Mode

Sets the mode in which data values are interpreted to be ASCII. Only unsigned integer values (0 – 65535) are allowed in this mode and the data values are terminated with a carriage return (ASCII 13) or linefeed (ASCII 10). In this mode the Flame “echoes” the command and data values back out the RS-232 port.

Command Syntax:	aA
Response:	ACK or NAK
Default value	N/A

! The command requires that the string “aA” be sent without any CR or LF. This is an attempt to insure that this mode is not entered inadvertently.

A legible response to the Version number query (v command) indicates the Flame is in the ASCII data mode.

Binary Data Mode

Sets the mode in which data values are interpreted to be binary. Only 16 bit unsigned integer values (0 – 65535) are allowed in this mode with the MSB followed by the LSB

Command Syntax:	bB
Response:	ACK or NAK
Default value	Default at power up – not changed by Q command

! The command requires that the string “bB” be sent without any CR or LF. This is an attempt to insure that this mode is not entered inadvertently.

Checksum Mode

Specifies whether the Flame will generate and transmit a 16-bit checksum of the spectral data. This checksum can be used to test the validity of the spectral data, and its use is recommended when reliable data scans are required.

Command Syntax:	k{DATA WORD}
Value:	0 = Do not transmit checksum value !0 = transmit checksum value at end of scan
Response:	ACK or NAK
Default value:	0

Version Number Query

Returns the version number of the code running on the microcontroller. A returned value of 1000 is interpreted as 1.00.0.

Command Syntax:	v
Response:	ACK followed by {DATA WORD}
Default value	N/A

Calibration Constants

Writes one of the 16 possible calibration constant to EEPROM. The calibration constant is specified by the first DATA WORD which follows the x. The calibration constant is stored as an ASCII string with a max length of 15 characters. The string does not check to see if it makes sense.

Command Syntax:	x{DATA WORD}{ASCII STRING}
Value:	<p>DATA WORD Index description</p> <p>0 – Serial Number</p> <p>1 – 0th order Wavelength Calibration Coefficient</p> <p>2 – 1st order Wavelength Calibration Coefficient</p> <p>3 – 2nd order Wavelength Calibration Coefficient</p> <p>4 – 3rd order Wavelength Calibration Coefficient</p> <p>5 – Stray light constant</p> <p>6 – 0th order non-linearity correction coefficient</p> <p>7 – 1st order non-linearity correction coefficient</p> <p>8 – 2nd order non-linearity correction coefficient</p> <p>9 – 3rd order non-linearity correction coefficient</p> <p>10 – 4th order non-linearity correction coefficient</p> <p>11 – 5th order non-linearity correction coefficient</p> <p>12 – 6th order non-linearity correction coefficient</p> <p>13 – 7th order non-linearity correction coefficient</p> <p>14 – Polynomial order of non-linearity calibration</p> <p>15 – Optical bench configuration: gg fff sss gg – Grating #, fff – filter wavelength, sss – slit size</p> <p>16 – Flame configuration: AWL V A – Array coating Mfg, W – Array wavelength (VIS, UV, OFLV), L – L2 lens installed, V – CPLD Version</p> <p>17 – Reserved</p> <p>18 – Reserved</p> <p>19 – Reserved</p>
Response:	ACK or NAK
Default value:	N/A

To query the constants, use the ?x{DATA WORD} format to specify the desired constant

Query Variable

Returns the current value of the parameter specified. The syntax of this command requires two ASCII characters. The second ASCII character corresponds to the command character which

sets the parameter of interest (acceptable values are B, A, I, K, T, J, y). A special case of this command is ?x (lower case) which requires an additional data word be passed to indicate which calibration constant is to be queried.

Command Syntax:	?{ASCII character}
Response:	ACK followed by {DATA WORD}
Default value:	N/A

FLAME-T Firmware

Hardware Description

The Flame utilizes a Cypress FX2 microcontroller, which has a high speed 8051, combined with an USB ASIC. Program code and data coefficients are stored in external E2PROM, which are loaded at boot-up via the I2C bus.

Spectral Memory Storage

The Flame can store a single spectrum in the spectral data section. While spectra are being accumulated, it is being co-added to the existing spectra in memory. With this approach it is capable to accumulate any number of spectra (previous limit was 4).

USB Information

Ocean Optics Vendor ID number is 0x2457 and the Product ID is 0x1022.

Instruction Set

Command Syntax

The list of the commands is shown in the following table followed by a detailed description of each command. The length of the data depends on the command. All commands are sent to the Flame through End Point 1 Out (EP1). All spectra data is acquired through End Point 2 and 6 In and all other queries are retrieved through End Point 1 In (EP1). The endpoints enabled and their order is:

Pipe #	Description	Type	Hi Speed Size (Bytes)	Full Speed Size (Bytes)	Endpoint Address
0	End Point 1 Out	Bulk	512	64	0x01
1	End Point 2 In	Bulk	512	64	0x82
2	End Point 6 In	Bulk	512	64	0x86
3	End Point 1 In	Bulk	512	64	0x81

USB Command Summary

EP2 Command Byte Value	Description
0x01	Initialize Flame
0x02	Set Integration Time
0x03	Set Strobe Enable Status
0x05	Query Information
0x06	Write Information
0x09	Request Spectra
0x0A	Set Trigger Mode
0x0B	Query number of Plug-in Accessories Present
0x0C	Query Plug-in Identifiers
0x0D	Detect Plug-ins
0x12	LED Status
0x60	General I ² C Read
0x61	General I ² C Write
0x62	General SPI I/O
0x68	PSOC Read
0x69	PSOC Write
0x6A	Write Register Information
0x6B	Read Register Information
0x6C	Read PCB Temperature
0x6D	Read Irradiance Calibration Factors
0x6E	Write Irradiance Calibration Factors
0xFE	Query Information

USB Command Descriptions

A detailed description of all Flame commands follows. While all commands are sent to EP1 over the USB port, the byte sequence is command dependent. The general format is the first byte is the command value and the additional bytes are command specific values.

Byte 0	Byte 1	Byte 2	...	Byte n-1
Command Byte	Command Specific	Command Specific	...	Command Specific

Initialize Flame

Initializes certain parameters on the Flame and sets internal variables based on the USB communication speed the device is operating at. This command should be called at the start of every session however if the user does not call it, it will be executed on the first Request Scan command. The default vales are set as follows:

Parameter	Default Value
Trigger Mode	0 – Normal Trigger

Byte Format

Byte 0
0x01

Set Integration Time

Sets the Flame integration time in microseconds. The value is a 32-bit value whose acceptable range is 10 – 65,535,000µs. If the value is outside this range the value is unchanged. For integration times less than 655,000µs, the integration counter has a resolution of 10µs. For integration times greater than this, the integration counter has a resolution of 1ms.

Byte Format

Byte 0	Byte 1	Byte 2	Byte 3	Byte 4
0x02	LSW-LSB	LSW-MSB	MSW-LSB	MSW-LSB

MSW & LSW: Most/Least Significant Word

MSB & LSB: Most/Least Significant Byte

Set Strobe Enable Status

Sets the Flame Lamp Enable line (J2 pin 4) as follows. The Single Strobe and Continuous Strobe signals are enabled/disabled by this Lamp Enable Signal.

Data Byte = 0 → Lamp Enable Low/Off
Data Byte = 1 → Lamp Enable HIGH/On

Byte Format

Byte 0	Byte 1	Byte 2
0x03	Data byte LSB	Data Byte MSB

Query Information

Queries any of the 31 stored spectrometer configuration variables. The Query command is sent to End Point 1 Out and the data is retrieved through End Point 1 In. When using Query Information to read EEPROM slots, data is returned as ASCII text. However, everything after the first byte that is equal to numerical zero will be returned as garbage and should be ignored.

The 31 configuration variables are indexed as follows:

Data Byte - Description
0 – Serial Number
1 – 0 th order Wavelength Calibration Coefficient
2 – 1 st order Wavelength Calibration Coefficient
3 – 2 nd order Wavelength Calibration Coefficient
4 – 3 rd order Wavelength Calibration Coefficient
5 – Stray light constant
6 – 0 th order non-linearity correction coefficient
7 – 1 st order non-linearity correction coefficient
8 – 2 nd order non-linearity correction coefficient
9 – 3 rd order non-linearity correction coefficient
10 – 4 th order non-linearity correction coefficient
11 – 5 th order non-linearity correction coefficient
12 – 6 th order non-linearity correction coefficient
13 – 7 th order non-linearity correction coefficient
14 – Polynomial order of non-linearity calibration
15 – Optical bench configuration: gg fff sss gg – Grating #, fff – filter wavelength, sss – slit size
16 – Flame configuration: AWL V A – Array coating Mfg, W – Array wavelength (VIS, UV, OFLV), L – L2 lens installed, V – CPLD Version
17 – Autonulling information
18 – Power-up baud rate value
19-30 – User-configured

Byte Format

Byte 0	Byte 1
0x05	Data byte

Return Format (EP1)

The data is returned in ASCII format and read in by the host through End Point 1.

Byte 0	Byte 1	Byte 2	Byte 3	...
0x05	Configuration Index	ASCII byte 0	ASCII byte 1	...

Write Information

Writes any of the 31 stored spectrometer configuration variables to EEPROM. The 31 configuration variables are indexed as described in the Query Information. The information to be written is transferred as ASCII information.

Byte Format

Byte 0	Byte 1	Byte 2	Byte 3	...	Byte 17
0x06	Configuration Index	ASCII byte 0	ASCII byte 1	...	ASCII byte 15

Request Spectra

Initiates a spectral acquisition. The Flame will acquire a complete spectrum (3840 pixel values). The data is returned in bulk transfer mode through EP2 and EP6 depending on the USB Communication Speed. The table below provides the pixel order overview for the 2 different speeds. The pixel values are decoded as described below.

Byte Format

Byte 0
0x09

Return Format

The format for the returned spectral data is dependent upon the USB communication speed. The format for both High Speed (480 Mbps) and Full Speed (12Mbps) is shown below. All pixel values are 16 bit values which are organized in LSB | MSB order. There is an additional packet containing one value that is used as a flag to insure proper synchronization between the PC and Flame.

USB High Speed (480Mbps) Packet Format

In this mode, the first 2K worth of data is read from EP6In and the rest is read from EP2In. The packet format is described below.

8: Firmware and Advanced Communications

Packet #	End Point	# Bytes	Pixels
0	EP6In	512	0-255
1	EP6In	512	256-511
2	EP6In	512	512-767
3	EP6In	512	768-1023
4	EP2In	512	1024-1279
5	EP2In	512	1280-1535
...	EP2In	512	
14	EP2In	512	3584-3840
15	EP2In	1	Sync Packet

The format for the first packet is as follows (all other packets except the synch packet has a similar format except the pixel numbers are incremented by 256 pixels for each packet).

Packet 0

Byte 0	Byte 1	Byte 2	Byte 3
Pixel 0 LSB	Pixel 0 MSB	Pixel 1 LSB	Pixel 2 MSB
...			
		Byte 510	Byte 511
		Pixel 255 LSB	Pixel 255 MSB

Packet 15 – Synchronization Packet (1 byte)

Byte 0
0x69

USB Full Speed (12Mbps) Packet Format

In this mode all data is read from EP2In. The pixel and packet format is shown below.

Packet #	End Point	# Bytes	Pixels
0	EP2In	64	0-31
1	EP2In	64	32-63
2	EP2In	64	64-95
...	EP2In	64	
119	EP2In	64	3808-3839
120	EP2In	1	Sync Packet

Packet 0

Byte 0	Byte 1	Byte 2	Byte 3
Pixel 0 LSB	Pixel 0 MSB	Pixel 1 LSB	Pixel 2 MSB
...			
		Byte 62	Byte 63
		Pixel 31 LSB	Pixel 31 MSB

Packet 120 – Synchronization Packet (1 byte)

Byte 0
0x69

Set Trigger Mode

Sets the Flame Trigger mode to one of the following states. If an unacceptable value is passed, then the trigger state is unchanged.

Data Value = 0 → Normal (Free running) Mode
Data Value = 1 → Software Trigger Mode
Data Value = 2 → External Synchronization Trigger Mode
Data Value = 3 → External Hardware Trigger Mode

Byte Format

Byte 0	Byte 1	Byte 2
0x0A	Data Value LSB	Data Value MSB

Query Number of Plug-in Accessories

Queries the number of Plug-in accessories preset. This is determined at power up and whenever the Plug-in Detect command is issued.

Byte Format

Byte 0
0x0B

Return Format

The data is returned in Binary format and read in by the host through End Point 7.

Byte 0
Value (BYTE)

Query Plug-in Identifiers

Queries the Plug-in accessories identifiers. This command returns 7 bytes with the last byte always being zero at this point. Each of the first 6 bytes correspond to Ocean Optics compatible devices which responded appropriately for I²C addresses 2 through 7 respectively. The I²C address are reserved for various categories of devices and the value for each category is shown below. I²C addresses 0-1 are reserved for loading program code from EEPROMS.

Byte Format

Byte 0
0x0C

Return Format

The data is returned in Binary format and read in by the host through End Point 7.

Byte 0	Byte 1	...	Byte 5	Byte 6
Value @ I ² C address 2	Value @ I ² C address 3	...	Value @ I ² C address 7	0x00

Detect Plug-ins

Reads all of the plug-in accessories that are plugged into the I²C bus. No data values are returned.

Byte Format

Byte 0
0x0D

LED Status

Sets the Flame LEDs as follows.

Data Byte = 0 → LEDs Off
Data Byte = 1 → LEDs On

Byte Format

Byte 0	Byte 1
0x12	Data byte

General I2C Read

Performs a general purpose read on the I2C pins for interfacing to attached peripherals. The time to complete the command is determined by the amount of data transferred and the response time of the peripheral. The I2C bus runs at 400KHz. The maximum number of bytes that can be read is 61.

Command Byte Format

Byte 0	Byte 1	Byte 2
0x60	I ² C Address	Bytes to Read

Return Byte Format

Byte 0	Byte 1	Byte 2	Byte 3	...	Byte N+3
I ² C Results	I ² C Address	Bytes to Read	Data Byte 0	...	Data byte N

I ² C Result Value	Description
0	I ² C bus Idle
1	I ² C bus Sending Data
2	I ² C bus Receiving Data
3	I ² C bus Receiving first byte of string
5	I ² C bus in waiting for STOP condition
6	I ² C experienced Bit Error
7	I ² C experience a Not Acknowledge (NAK) Condition
8	I ² C experienced successful transfer
9	I ² C bus timed out

General I2C Write

Performs a general purpose write on the I²C pins for interfacing to attached peripherals. The time to complete the command is determined by the amount of data transferred and the response time of the peripheral. The I²C bus runs at 400KHz. The results codes are described above.

Command Byte Format

Byte 0	Byte 1	Byte 2	Byte 3	...	Byte N+3
0x61	I ² C Address	Bytes to Write	Data Byte 0	...	Data byte N

Return Byte Format

Byte 0
I ² C Results

General SPI Input/Output

Performs a general-purpose write and read on the SPI bus for interfacing to attached peripherals. The time to complete the command is determined by the amount of data transferred and the response time of the peripheral. The SPI bus runs at ~25KHz Clock. The maximum number of bytes that can be written or read is 61. During this transfer the SPI Chip Select signal is driven to an active LOW TTL level. Data is transmitted out the MOSI (Master Out Slave In) line on the rising edge of the clock signal. Data is also latched in the from the MISO line on the falling edge of the clock signal.

Command Byte Format

Byte 0	Byte 1	Byte 2	Byte 3	...	Byte N+2
0x62	# of Bytes (N)	Write Byte 0	Write Byte 1	...	Write Byte N

Return Byte Format

Byte 0	Byte 1	Byte 2	Byte 3	...	Byte N+1
# of Bytes (N)	Read Byte 0	Read Byte 1	Read Byte 2	...	Read Byte N

Write Register Information

Most all of the controllable parameters for the Flame are accessible through this command (e.g., GPIO, strobe parameters, etc.). A complete list of these parameters with the associate register information is shown in the table below. Commands are written to End Point 1 Out typically with 4 bytes (some commands may require more data bytes). All data values are 16 bit values transferred in MSB | LSB order. This command requires 100µs to complete; the calling program needs to delay for this length of time before issuing another command. In some instances, other commands will also write to these registers (i.e., integration time), in these cases the user has the options of setting the parameters through 2 different methods.

Byte Format

Byte 0	Byte 1	Byte 2	Byte 3
0x6A	Register Value	Data Byte LSB	Data Byte MSB

Register Address	Description	Default Value	Min Value	Max Value	Time Base
0x00*	Master Clock Counter Divisor	24	1	0xFFFF	48MHz
0x04	FPGA Firmware Version (Read Only)				
0x08	Continuous Strobe Timer Interval Divisor	48000	0	0xFFFF	Continuous Strobe Base Clock (see Register 0x0C)
0x0C	Continuous Strobe Base Clock Divisor	4800	0	0xFFFF	48MHz
0x10*	Integration Period Base Clock Divisor	480	0	0xFFFF	48MHz
0x14	Set base_clk or base_clkx2 0: base_clk 1: base_clkx2	0	0	1	N/A
0x18*	Integration Clock Timer Divisor	600	0	0xFFFF	Integration Period Base Clock (see Register 0x10)
0x20	Reserved				
0x28	Hardware Trigger Delay – Number of Master Clock cycles to delay when in External Hardware Trigger mode before the start of the integration period	0	0	0xFFFF	2MHz
0x2C*&	Trigger Mode 0 = Free Running 1 = External Synchronization 2 = External Hardware Trigger	0	0	2	N/A
0x30	Reserved				

8: Firmware and Advanced Communications

Register Address	Description	Default Value	Min Value	Max Value	Time Base
0x38	Single Strobe High Clock Transition Delay Count	1	0	0xFFFF	2MHz
0x3C	Single Strobe Low Clock Transition Delay Count	5	0	0xFFFF	2MHz
0x40	Lamp Enable	0	0	1	N/A
0x48	GPIO Mux Register 0: pin is GPIO pin 1: pin is alternate function	0	0	0x03FF	N/A
0x50	GPIO Output Enable 1: pin is output 0: pin is input	0	0	0x03FF	N/A
0x54	GPIO Data Register For Output: Write value of signal For Input: Read current GPIO state	0	0	0x03FF	N/A
0x58	Reserved				
0x5C	Reserved				
0x74	Offset Value	0	0	0xFFFF	N/A
0x78	Offset Control Bit 0 = Enable Auto-Nulling Bit 1 = Enable Auto-Nulling Saturation	0	0	0xFFFF	N/A
0x7C	FPGA Programmed (Read Only)	0x5501	N/A	N/A	N/A
0x80	Maximum Saturation Level	0x55F0	0	0xFFFF	N/A

Notes: * - User should not change these values because spectrometer performance can be affected. This information is included just for completeness
 & - These values are controlled by other command interfaces to the Flame (i.e., Set integration time command).

Read Register Information

Reads the values from any of the registers above. This command is sent to End Point 1 Out and the data is retrieved through End Point 1 In.

Byte Format

Byte 0	Byte 1
0x6B	Register Value

Return Format (EP1In)

Byte 0	Byte 1	Byte 2
Register Value	Value MSB	Value LSB

Read PCB Temperature

Reads the Printed Circuit Board temperature. The Flame contains a DS1721 temperature sensor chip which is mounted to the underside of the PCB. This command is sent to End Point 1 Out and the data is retrieved through End Point 1 In. The value returned is a signed 16-bit A/D conversion value, which is equated to temperature by:

$$\text{Temperature (}^{\circ}\text{C)} = .003906 * \text{ADC Value}$$

Byte Format

Byte 0
0x6C

Return Format (EP1In)

Byte 0	Byte 1	Byte 2
Read Result	ADC Value LSB	ADC Value MSB

If the operation was successful, the Read Result byte value will be 0x08. All other values indicate the operation was unsuccessful.

Read Irradiance Factors

Reads 60 bytes of data, which is utilized for Irradiance Calibration information from the desired EEPROM memory address.

8: Firmware and Advanced Communications

Byte Format

Byte 0	Byte 1	Byte 2
0x6D	EEPROM Address LSB	EEPROM Address MSB

Return Byte Format

Byte 0	Byte 1	...	Byte 59
Byte 0	Byte 1	...	Byte 59

Write Irradiance Factors

Write 60 bytes of data, which is used for Irradiance Calibration information to the desired EEPROM memory address.

Byte Format

Byte 0	Byte 1	Byte 2	Byte 3	...	Byte 62
0x6E	EEPROM Address LSB	EEPROM Address MSB	Byte 0	...	Byte 59

Query Status

Returns a packet of information containing the current operating information. The structure of the status packet is given below:

Byte Format

Byte 0
0xFE

Return Format

The data is returned in Binary format and read in by the host through End Point 1 In. The structure for the return information is as follows:

Byte	Description	Comments
0-1	Number of Pixels - WORD	LSB MSB order
2-5	Integration Time - WORD	Integration time in μs – LSW MSW. Within each word order is LSB MSB

Byte	Description	Comments
6	Lamp Enable	0 – Signal LOW 1 – Signal HIGH
7	Trigger Mode Value	
8	Spectral Acquisition Status	
9	Packets In Spectra	Returns the number of Packets in a Request Spectra Command.
10	Power Down Flag	0 – Circuit is powered down 1 – Circuit is powered up
11	Packet Count	Number of packets that have been loaded into End Point Memory
12	Reserved	
13	Reserved	
14	USB Communications Speed	0 – Full Speed (12Mbps) 0x80 – High Speed (480 Mbps)
15	Reserved	

Flame –T Serial Port Interface Communications and Control Information

The Flame is a microcontroller-based Miniature Fiber Optic, which can communicate via the Universal Serial Bus or RS-232. This document contains the necessary command information for controlling the Flame via the RS-232 interface.

Hardware Description

The Flame utilizes a Cypress FX2 microcontroller, which has a high speed 8051, combined with an USB ASIC. Program code and data coefficients are stored in external E²PROM, which are loaded at boot-up via the I²C bus.

Spectral Memory Storage

The Flame can store a single spectrum in the spectral data section. While spectra are being accumulated, it is being co-added to the existing spectra in memory.

Instruction Set

Command Syntax

The list of the commands is shown in the following table along with the microcode version number they were introduced with. All commands consist of an ASCII character passed over the serial port, followed by some data. The length of the data depends on the command. The format for the data is either ASCII or binary (default). The ASCII mode is set with the “a”

command and the binary mode with the “b” command. To insure accurate communications, all commands respond with an ACK (ASCII 6) for an acceptable command or a NAK (ASCII 21) for an unacceptable command (i.e. data value specified out of range).

In the ASCII data value mode, the Flame “echoes” the command back out the RS-232 port. In binary mode all data, except where noted, passes as 16-bit unsigned integers (WORDS) with the MSB followed by the LSB. By issuing the “v command” (Version number query), the data mode can be determined by viewing the response (ASCII or binary).

In a typical data acquisition session, the user sends commands to implement the desired spectral acquisition parameters (integration time, etc.). Then the user sends commands to acquire spectra (S command) with the previously set parameters. If necessary, the baud rate can be changed at the beginning of this sequence to speed up the data transmission process.

Command Summary

Letter	Description	Version
A	Adds scans	1.00.0
B	Set Pixel Boxcar	1.00.0
C		
D		
E		
F		
G	Set Data Compression	1.00.0
H		
I	Sets integration time (ms increments)	1.00.0
J	Sets Lamp Enable Signal	1.00.0
K	Changes baud rate	1.00.0
L	Clear Memory	
M		
N		
O		
P	Partial Pixel Mode	1.00.0
Q		
R		
S	Starts spectral acquisition with previously set parameters	1.00.0
T	Sets trigger mode	1.00.0
U		
V		
W	Set FPGA Register Information	1.00.0

Letter	Description	Version
X		
Y		
Z	Read out Scan from memory	1.00.0
A	Set ASCII mode for data values	1.00.0
b	Set binary mode for data values	1.00.0
i	Set integration value (32-bit value and us increments)	1.00.0
k	Sets Checksum mode	1.00.0
v	Provides microcode version #	1.00.0
x	Sets calibration coefficients	1.00.0
?	Queries parameter values	1.00.0
+	Reads the plugged-in accessories	1.00.0

Command Descriptions

A detailed description of all Flame commands follows. The {} indicates a data value which is interpreted as either ASCII or binary (default). The default value indicates the value of the parameter upon power up.

Add Scans

Sets the number of discrete spectra to be summed together. Since the Flame has the ability to return 32 bit values, overflow of the raw 16-bit ADC value is not a concern.

Command Syntax:	A{DATA WORD}
Response:	ACK or NAK
Range:	1-5000
Default value:	1

Pixel Boxcar Width

Sets the number of pixels to be averaged together. A value of n specifies the averaging of n pixels to the right and n pixels to the left. This routine uses 32-bit integers so that intermediate overflow will not occur; however, the result is truncated to a 16-bit integer prior to transmission of the data. This math is performed just prior to each pixel value being transmitted out. Values greater than ~ 3 will exceed the idle time between values and slow down the overall transfer process.

Command Syntax:	B{DATA WORD}
Response:	ACK or NAK
Range:	0-15
Default value:	0

Set Data Compression

Specifies whether the data transmitted from the Flame should be compressed to speed data transfer rates. For more information on Flame Data Compression, see Technical Note 1.

Command Syntax:	G{DATA WORD}
Response:	ACK or NAK
Range:	0 – Compression off !0 – Compression on
Default value:	0

Integration Time (16 Bit)

Sets the Flame's integration time, in milliseconds, to the value specified. This command accepts just a 16-bit value and is expressed in ms for backward compatibility with the USB2000. Use the "i" command for full 32-bit functionality.

Command Syntax:	I{16 bit DATA WORD}
Response:	ACK or NAK
Range:	1 – 65,000,000
Default value:	6ms

Integration Time (32 Bit)

Sets the Flame's integration time, in microseconds, to the value specified.

Command Syntax:	i{32-bit DATA DWORD}
Response:	ACK or NAK
Range:	10 – 65,000,000
Default value:	6,000

Lamp Enable

Sets the Flame's Lamp Enable line to the value specified.

Command Syntax:	J{DATA WORD}
Value:	0 = Light source/strobe off—Lamp Enable low 1 = Light source/strobe on—Lamp Enable high
Response:	ACK or NAK
Default value:	0

Baud Rate

Sets the Flame's baud rate.

Command Syntax:	K{DATA WORD}
Value:	0=2400 1=4800 2=9600 3=19200 4=38400 5=Not Supported 6=115,200 7=230,400
Response:	See below
Default value:	2

When changing baud rates, the following sequence must be followed:

1. Controlling program sends K with desired baud rate, communicating at the old baud rate.
2. The Flame responds with ACK at old baud rate, otherwise it responds with NAK and the process is aborted.
3. Controlling program waits longer than 50 milliseconds.
4. Controlling program sends K, followed by the desired baud rate.

For example, to change the baud rate from 9600 to 115,200 in ASCII mode:

- At 9600 baud, send "K6<enter>"
 - You will receive an ACK at 9600 baud
 - Send "K6<enter>" at 115200. (Note that the "K" is not echoed back, but the "6" is)
 - You will receive two ACK characters and the prompt at 115200 baud.
5. The Flame responds with ACK at new baud rate, otherwise it responds with NAK and old baud rate is used.

Notes

If a deviation occurs at any step, the previous baud rate is used.

The power-up Baud rate can be set by setting the EEPROM Memory slot to the desired value (i.e., 6 for a value of 115,200 Baud)

Pixel Mode

Specifies which pixels are transmitted. While all pixels are acquired on every scan, this parameter determines which pixels will be transmitted out the serial port.

Command Syntax:	P{DATA WORD}	
Value:	Description 0 = all 3870 pixels 1 = every n th pixel with no averaging 2 = N/A 3 = pixel x through y every n pixels 4 = up to 10 randomly selected pixels between 0 and 2047 (denoted p1, p2, ... p10)	Example P 0 (spaces for clarity only) P 1<Enter> N<Enter> P 2 N/A P3<Enter> x<Enter> y<Enter> n<Enter> P 4<Enter> n<Enter> p1<Enter> p2<Enter> p3<Enter> ... p10<Enter>
Response:	ACK or NAK	
Default value:	0	

Note

Since most applications only require a subset of the spectrum, this mode can greatly reduce the amount of time required to transmit a spectrum while still providing all of the desired data. This mode is helpful when interfacing to PLCs or other processing equipment.

Spectral Acquisition

Acquires spectra with the current set of operating parameters. When executed, this command determines the amount of memory required. If sufficient memory does not exist, an ETX (ASCII 3) is immediately returned and no spectra are acquired. An STX (ASCII 2) is sent once the data is acquired and stored. If the Data Storage Mode value is 0, then the data is transmitted immediately. If the Scans to Accumulate is 1, then the data is returned as WORDs. However, if it is greater than 1, then the data is returned as DWORDs to avoid overflow.

Command Syntax:	S
Response:	If successful, STX followed by data If unsuccessful, ETX

The format of returned spectra includes a header to indicate scan number, channel number, pixel mode, etc. The format is as follows:

- WORD 0xFFFF – start of spectrum
- WORD Data size flag (0=Data is WORDs, 1=Data is DWORDs)
- WORD Number of Scans Accumulated
- WORD Integration time in milliseconds
- WORD FPGA Established Baseline value (MSW)
- WORD FPGA Established Baseline value (MSW)
- WORD pixel mode
- WORDS if pixel mode not 0, indicates parameters passed to the Pixel Mode command (P)
- (D)WORDS spectral data depending on Data size flag
- WORD 0xFFFD – end of spectrum

Trigger Mode

Sets the Flame’s external trigger mode to the value specified.

Command Syntax:	T{DATA WORD}
Value:	0 = Normal – Continuously scanning 1 = Software trigger 2 = External Synchronization 3 = External Hardware Trigger
Response:	ACK or NAK
Default value:	0

ASCII Data Mode

Sets the mode in which data values are interpreted to be ASCII. Only unsigned integer values (0 – 65535) are allowed in this mode and the data values are terminated with a carriage return (ASCII 13) or linefeed (ASCII 10). In this mode the Flame “echoes” the command and data values back out the RS-232 port.

Command Syntax:	aA
Response:	ACK or NAK
Default value	N/A

Note

The command requires that the string “aA” be sent without any CR or LF. This is an attempt to insure that this mode is not entered inadvertently.

A legible response to the Version number query (v command) indicates the Flame is in the ASCII data mode.

Binary Data Mode

Sets the mode in which data values are interpreted to be binary. Only 16 bit unsigned integer values (0 – 65535) are allowed in this mode with the MSB followed by the LSB.

Command Syntax:	bB
Response:	ACK or NAK
Default value	Default at power up – not changed by Q command

Note

The command requires that the string “bB” be sent without any CR or LF. This is an attempt to insure that this mode is not entered inadvertently.

Checksum Mode

Specifies whether the Flame will generate and transmit a 16-bit checksum of the spectral data. This checksum can be used to test the validity of the spectral data, and its use is recommended when reliable data scans are required.

Command Syntax:	k{DATA WORD}
Value:	0 = Do not transmit checksum value !0 = transmit checksum value at end of scan
Response:	ACK or NAK
Default value:	0

Version Number Query

Returns the version number of the code running on the microcontroller. A returned value of 1000 is interpreted as 1.00.0

Command Syntax:	v
Response:	ACK followed by {DATA WORD}
Default value	N/A

Set FPGA Register Value

Sets the appropriate register within the FPGA. The list of register setting is in the USB command set information. This command requires two data values, one to specify the register and the next to specify the value.

Command Syntax:	W{DATA WORD 1}{DATA WORD 2}
Value:	Data Word 1 – FPGA Register address Data Word 2 – FPGA Register Value
Response:	ACK or NAK
Default value:	N/A

ASCII Data Mode

Sets the mode in which data values are interpreted to be ASCII. Only unsigned integer values (0 – 65535) are allowed in this mode and the data values are terminated with a carriage return (ASCII 13) or linefeed (ASCII 10). In this mode the Flame “echoes” the command and data values back out the RS-232 port.

Command Syntax:	aA
Response:	ACK or NAK
Default value	N/A

Note

This command requires that the string “aA” be sent without any CR or LF. This is an attempt to ensure that this mode is not entered inadvertently. A legible response to the version number query (v command) indicates the Flame is in the ASCII data mode.

Binary Data Mode

Sets the mode in which data values are interpreted to be binary. Only 16 bit unsigned integer values (0 – 65535) are allowed in this mode with the MSB followed by the LSB.

Command Syntax:	bB
Response:	ACK or NAK
Default value	Default at power up – not changed by Q command

Note

The command requires that the string “bB” be sent without any CR or LF. This is an attempt to insure that this mode is not entered inadvertently.

Checksum Mode

Specifies whether the Flame will generate and transmit a 16-bit checksum of the spectral data. This checksum can be used to test the validity of the spectral data, and its use is recommended when reliable data scans are required. See Technical Note 2 for more information on checksum calculation.

Command Syntax:	k{DATA WORD}
Value:	0 = Do not transmit checksum value !0 = transmit checksum value at end of scan
Response:	ACK or NAK
Default value:	0

Version Number Query

Returns the version number of the code running on the microcontroller. A returned value of 1000 is interpreted as 1.00.0.

Command Syntax:	v
Response:	ACK followed by {DATA WORD}
Default value	N/A

Calibration Constants

Writes one of the 32 possible calibration constant to EEPROM. The calibration constant is specified by the first DATA WORD which follows the x. The calibration constant is stored as an ASCII string with a max length of 15 characters. The string is not check to see if it makes sense.

Command Syntax:	x{DATA WORD}{ASCII STRING}
Value:	DATA WORD Index description 0 – Serial Number 1 – 0 th order Wavelength Calibration Coefficient 2 – 1 st order Wavelength Calibration Coefficient 3 – 2 nd order Wavelength Calibration Coefficient 4 – 3 rd order Wavelength Calibration Coefficient 5 – Stray light constant 6 – 0 th order non-linearity correction coefficient 7 – 1 st order non-linearity correction coefficient 8 – 2 nd order non-linearity correction coefficient 9 – 3 rd order non-linearity correction coefficient 10 – 4 th order non-linearity correction coefficient 11 – 5 th order non-linearity correction coefficient 12 – 6 th order non-linearity correction coefficient 13 – 7 th order non-linearity correction coefficient 14 – Polynomial order of non-linearity calibration 15 – Optical bench configuration: gg fff sss gg – Grating #, fff – filter wavelength, sss – slit size 16 – Flame configuration: AWL V A – Array coating Mfg, W – Array wavelength (VIS, UV, OFLV), L – L2 lens installed, V – CPLD Version 17 – Auto-nulling configuration information 18 – Startup Baud rate entry 19-30 – Reserved
Response:	ACK or NAK
Default value:	N/A

To query the constants, use the ?x{DATA WORD} format to specify the desired constant.

Query Variable

Returns the current value of the parameter specified. The syntax of this command requires two ASCII characters. The second ASCII character corresponds to the command character which sets the parameter of interest (acceptable values are B, A, I, K, T, J, y). A special case of this command is ?x (lower case) and ?W, which requires an additional data word be passed to indicate which calibration constant is to be queried.

Command Syntax:	?{ASCII character}
Response:	ACK followed by {DATA WORD}
Default value:	N/A

Examples

Below are examples on how to use some of the commands. Commands are in **BOLD** and descriptions are in parenthesis. For clarity, the commands are shown in the ASCII mode (a command) instead of the default binary mode. In ASCII mode, the Flame transmits a "> " prompt that is useful to determine when it is ready to accept a command.

The desired operating conditions are: acquire spectra from the spectrometer with a 20.150ms integration time, set number of scan to add to 5 and operate at 115,200 Baud.

```

aA          (Set ASCII Data Mode)
> K6<CR>    (Start baud rate change to 115,200)
                Wait for ACK, change to 115200, wait for 20ms
> K6<CR>    (Verify command, communicate at 115200)
> A5<CR>    (Add 5 spectra)
> i20150<CR> (Set integration time to 20.150ms)
S          (Acquire spectra)
...          Repeat as necessary
  
```

Application Tips

- During the software development phase of a project, the operating parameters of the Flame may become out-of-synch with the controlling program. It is good practice to cycle power on the Flame when errors occur.
- If you question the state of the Flame, you can transmit a space (or another non-command) using a terminal emulator. If you receive a NAK, the Flame is awaiting a command; otherwise, it is still completing the previous command.
- Use a terminal emulator and configure the following port settings:
 - a. Bits per second (Baud rate): Set to desired rate
 - b. Data bits: 8
 - c. Parity: None

8: Firmware and Advanced Communications

- d. Stop bits: 1
- e. Flow control: None

Index

A

absorbance, 17
accessories, 14, 17
accessory connector
 diagram, 49
acquisition
 continuous, 26
 single, 26
Acquisition Parameters, 25
application
 wizards, 28
applications, 3

B

breakout box, 16

C

cables
 DB15, 15
 PAK50, 16
calibration, 59
 irradiance, 63
 preparing for, 60
 procedure, 60
calibration coefficients
 saving in USB mode, 62
CCD, 52
 detector, 52
 detector reset, 54
 well depth, 52
compliance, vii

D

detector, 41
 specifications, 42
detector window, 42
document
 audience, v
 purpose, v
 summary, v
document version, vi

E

electrical pinout, 49
external triggering, 56

F

features, 2
fiber optic connector, 38
filter, 42
firmware, 65
 FLAME-S, 65
 FLAME-T, 91
fluorescence, 19

G

grating, 40

H

hardware
 features, 13
 setup, 11

I

I2C, 52
installation, 9
 software, 10
internal operation, 54
irradiance, 20
ISO certification, vii

L

LEDs, 13
lens, 41
longpass filter, 39

M

measurement
 dark, 29
 reference, 29
measurement techniques, 17
mechanical diagram, 48
memory chip, 59
methods, 28
mirror
 collimating, 39
 focusing, 41

O

OceanView, 11
 connect Flame, 25
 launch, 23
 main screen, 24
 product key, 32

P

packing list, 9
patent notice, vi
pixel definition, 54
product
 features, 2
 introduction, 1
 versions, 6
product-related documentation, vi
projects, 28

Q

Quick View mode, 26

R

Reflectance, 18
repairs, 34

S

schematic view, 29
serial port
 FLAME-S, 81
 FLAME-T, 105
servicing, 35
setup, 9
signal averaging, 53
slit, 16, 38
 change, 13
specifications, 45
 summary, 5
spectrometer
 how it works, 37
spectrometer configuration, 34
SPI, 51
strobe, 55
 continuous, 55
 single, 55
 synchronizing events, 55

T

- timing signals, 55
- transmission, 18
- triggering, 56
 - modes, 56
- troubleshooting, 31
 - Linux systems, 33
 - Mac systems, 33
 - Windows systems, 32
- typical set-ups, 17

U

- USB command summary
 - FLAME-T, 92
- USB Command Summary
 - FLAME-S, 66

W

- warranty, vi
- Wavelength Calibration
 - about, 59
- Wavelength Calibration Data File, 9
- Wavelength Calibration Data Sheet, 9
- wavelength range, 40

