

ECLIPSE E400

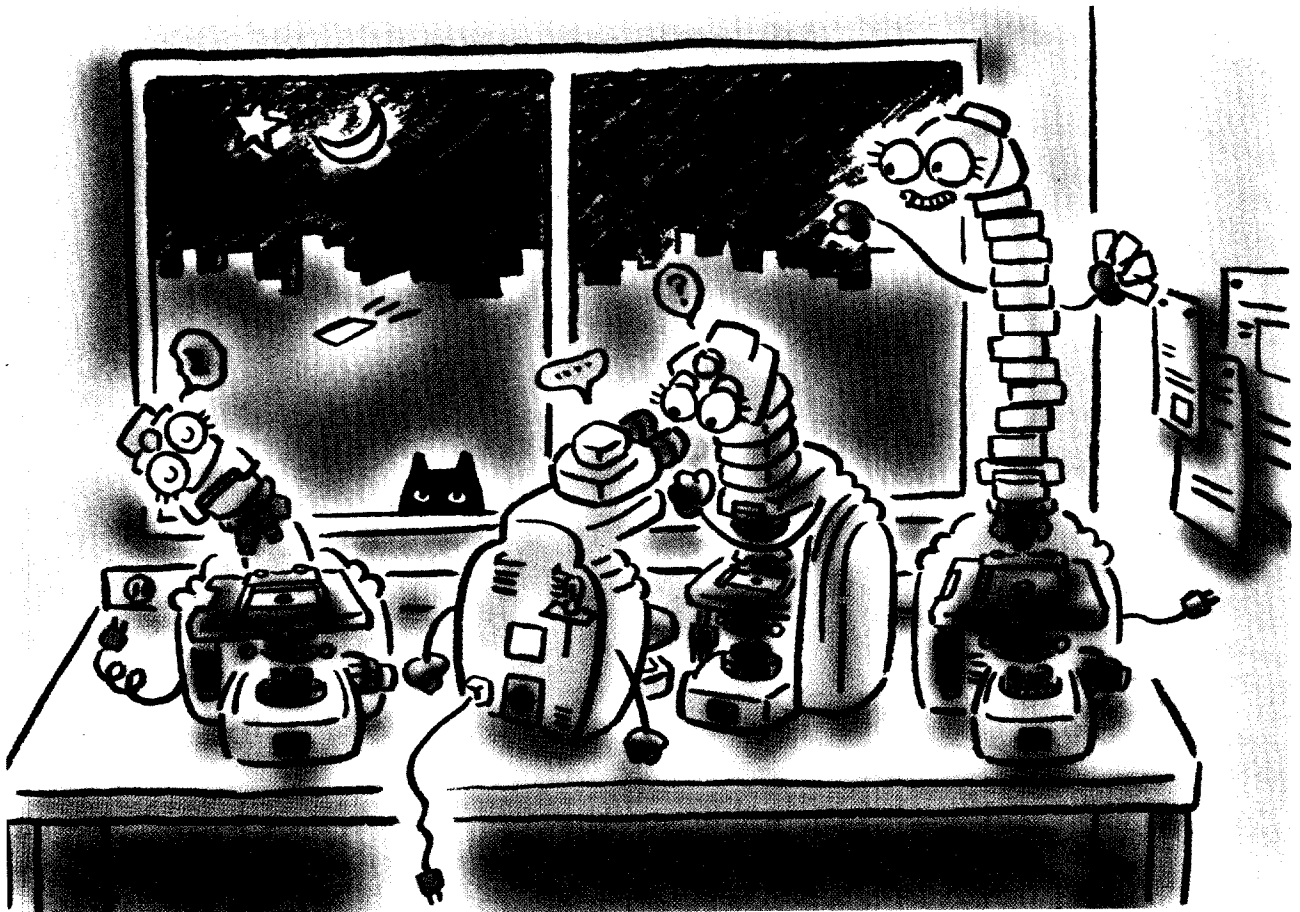

Instructions

Nikon

Before Using

Thank you for purchasing this Nikon product.

This instruction manual is written for the users of Nikon Microscope ECLIPSE E400.

To ensure correct usage read this manual carefully before operating the instrument.

- It is prohibited to reproduce or transmit this manual in part or whole without Nikon's expressed permission.
- The contents of this manual are subject to change without any notice.
- Although every effort has been made to ensure the accuracy of this manual, if you note any points that are unclear or incorrect, contact your nearest Nikon representative.

Warning/Caution Symbols in This Manual

Though Nikon products are designed to provide you utmost safety during use, incorrect usage or disregard of the instructions can cause personal injury or property damage. For your safety, read the instruction manual carefully and thoroughly before usage. Do not discard this manual but keep it near the product for easy reference.

Inside this instruction manual, safety instructions are indicated with the symbols shown below. Be sure to follow the instructions marked with these symbols for your safety.

Symbol

Contents



WARNING

Disregarding instructions marked with this symbol may lead to death or serious injury.



CAUTION

Disregarding instructions marked with this symbol may lead to injury or property damage.

Symbol on the product

Symbol

Contents



Caution for heat



WARNING



Intended product use

This microscope should only be used for microscopic observation. Do not use it for any other purpose.



Do not disassemble

Disassembly may cause malfunction and/or electrical shock. Do not disassemble any parts other than those mentioned in this manual. If you notice any malfunction, notify your nearest Nikon representative.

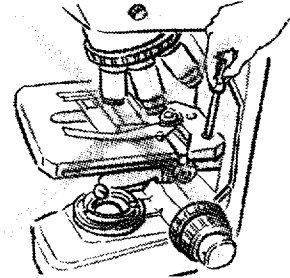

Confirm the input voltage

Make sure that the input voltage indicated on the back panel of the microscope is the same as your regional voltage. If not the same, do not use the microscope; instead, notify your nearest Nikon representative. If the microscope is used with the wrong input voltage, a short circuit or fire may result, causing the damage of the microscope.

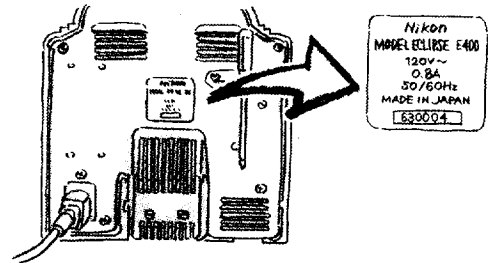

Power cord

To prevent electrical shock, always turn off the power switch (flip it to the " " side) before connecting or disconnecting the power cord. Use only the power cord provided with the microscope. (Refer to p. 24.) Using the wrong power cord could result in damage or fire.

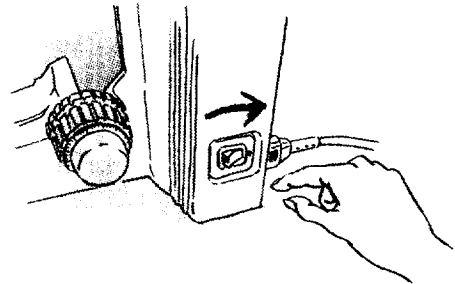

Heat from the light source

The lamp becomes extremely hot. To avoid burns, do not touch the lamp and the area around it while the lamp is lit or for about thirty minutes after the lamp has been turned off. Furthermore, in order to avoid the risk of fire, do not place fabric, paper or highly flammable materials (such as gasoline, petroleum benzene, paint thinner or alcohol) near the lamp while it is lit or for about thirty minutes after it has been turned off.

The back of the microscope also becomes hot during use. Although this is not a malfunction, be careful not to touch the back of the microscope when it is hot.

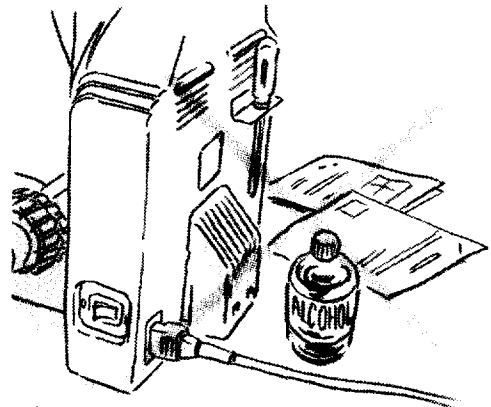



CAUTION



Installation location

This product is a precision optical instrument. Using or storing the instrument under unsuitable conditions may damage it or may have an adverse effect on its precision. The following conditions should be kept in mind when selecting the installation location.

- Avoid installing in a place exposed to direct sunlight, or directly under room lights or any other bright place. The quality of the view through the microscope deteriorates in bright surroundings.
- Install in a place with little dust and dirt.
- Install in a level place free from vibrations.
- Install on a sturdy desk or table that is able to bear the weight of the microscope.
- Do not install in a warm and humid location. Otherwise, condensation or mold may form on the lenses, degrading performance or damaging the equipment.



Check the light source

The power supply contained in the microscope provides the power for the halogen lamp as the microscope light source. Although this power supply can power a halogen lamp of up to 6 V-30 W, the specified lamp must be used. Use of a non-specified lamp could damage the microscope.

Specified lamp: 6 V-30 W (PHILIPS 5761)



Cautions when replacing the lamp

In order to prevent burns, allow the lamp to cool (for at least thirty minutes after turning off the power) before replacing the lamp. Furthermore, to prevent electrical shock and damage to the microscope, always turn off the power switch (flip it to the " " side) and unplug the power cord before replacing the lamp.

After replacing the lamp, be sure to attach the lamp cover securely. Never use the lamp without its cover.



Cautions when operating the stage

The stage rack protrudes outward when the stage is moved. When operating the focus knobs or condenser focus knob, be careful not to bump your hand on the rack since the end of the rack may injure your hand.

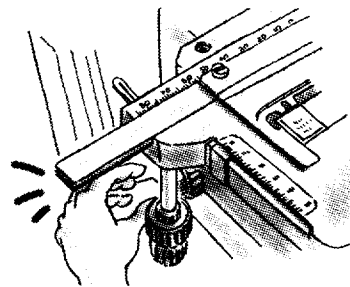

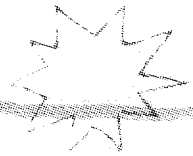
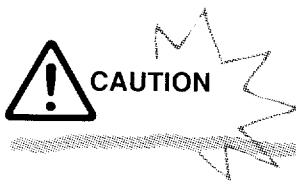

5

Do not wet

Spilling water on the microscope may cause electrical short circuits, resulting the microscope failure or abnormal heat generation. If, by mistake, water or liquid is spilled on the microscope, immediately turn off the power switch (flip it to the “ ” side) and unplug the power cord. Then use a dry cloth to wipe away the moisture. If any liquid gets inside of the microscope, do not attempt to use it; instead, contact your nearest Nikon representative.

6

Weak electromagnetic waves

This microscope emits weak electromagnetic waves. The accuracy of any precision electronic equipment may be adversely affected if positioned near this microscope. If this microscope affects TV or radio reception, move the radio or TV away from the microscope.

7

Notes on carrying the microscope

Securely hold onto the microscope with the base of the arm from the back of the microscope.

Because this microscope is a precision optical device, handle it carefully and do not subject it to strong physical shocks. (The precision of the objective in particular may be adversely affected by even weak physical shocks.)

In addition, do not grasp the focus knobs, the eyepiece tube, the stage, etc., when carrying the microscope; there is a chance that the part could come off, and the microscope could be damaged.

When picking up the microscope or putting it down, be careful not to bump the lamp cover on the back panel against other things.

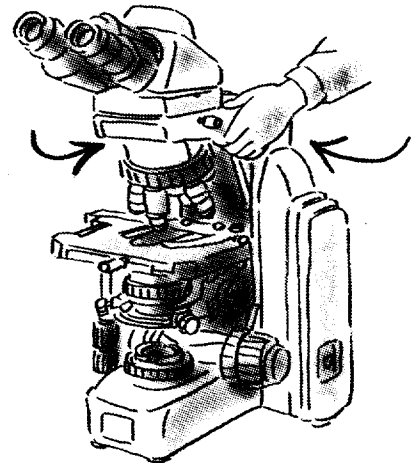

Names of Component Parts and Operational Parts

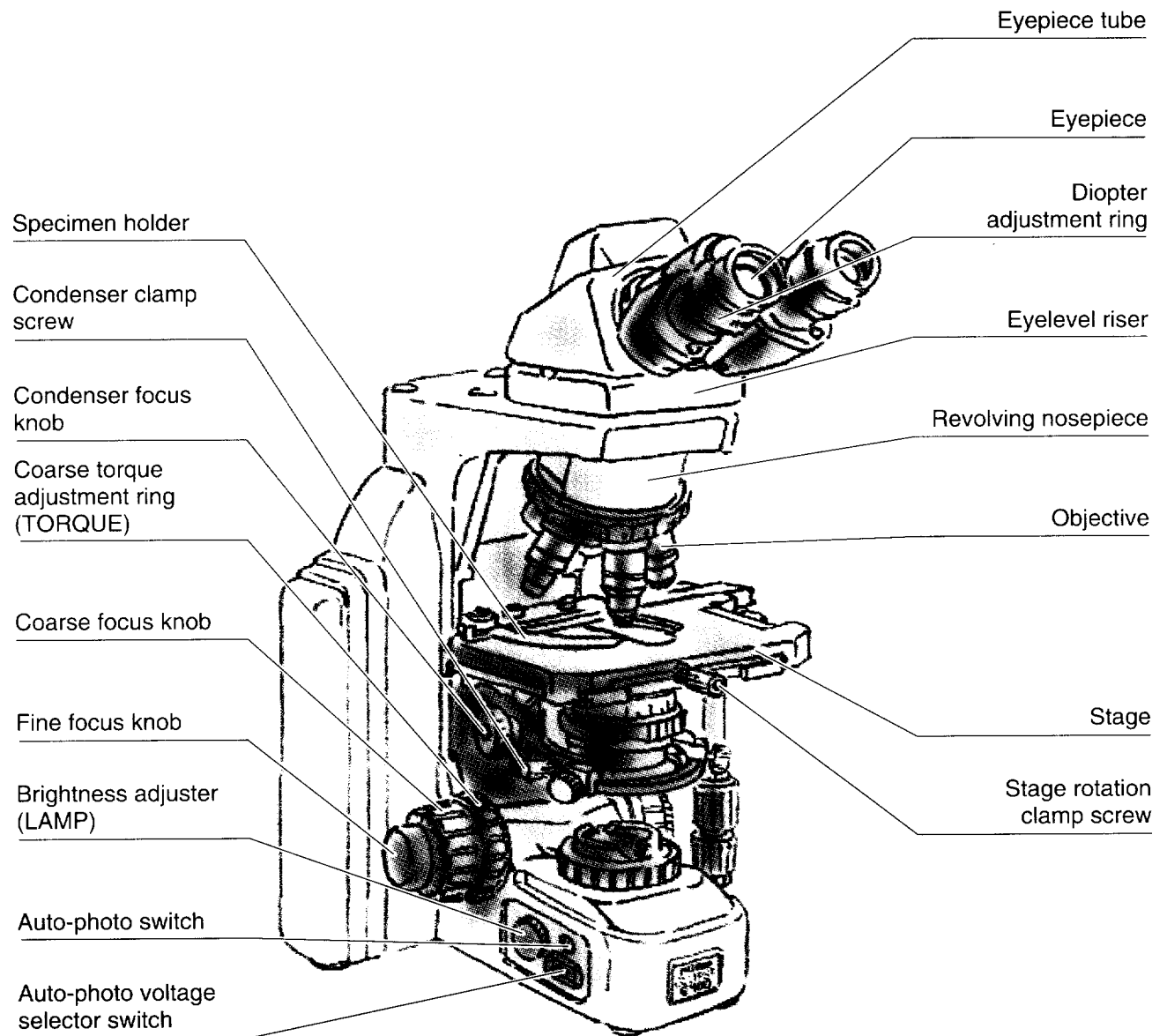

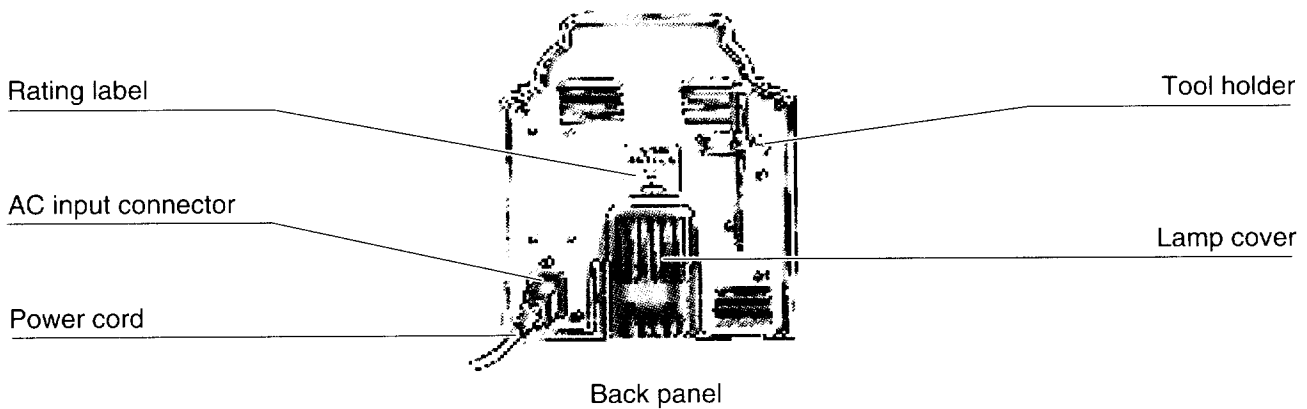
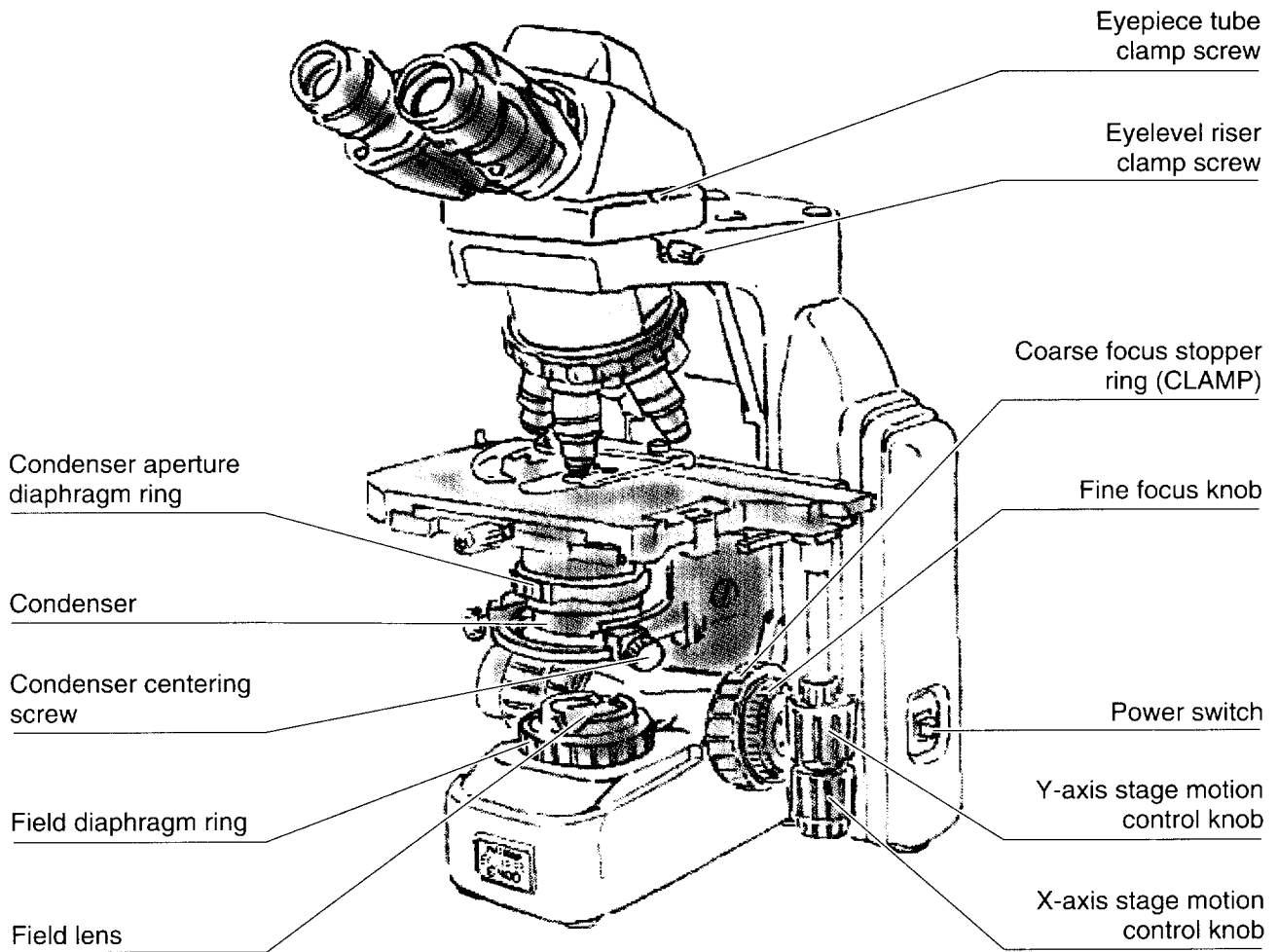

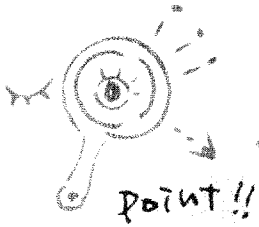

Proper Use Makes a Difference

Effect of Condenser Aperture Diaphragm



This adjustment should be made whenever the objective is changed. A well-defined image with appropriate contrast can be obtained with an aperture setting that is 70% to 80% of the objective numerical aperture. P.16



Stopped down too far

Excessive contrast and details cannot be seen



Suitable aperture setting

Appropriate contrast and well-defined image



Open too far

Insufficient contrast

Effect of Diopter Adjustment



Perform diopter adjustment for both eyepieces before beginning microscopy. In addition to making observation through both eyes easier, making this adjustment correctly also reduces the defocusing when changing the objective. P.14

Proper adjustment

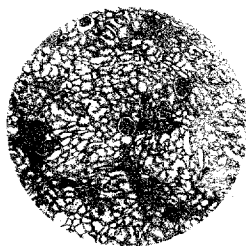

4x

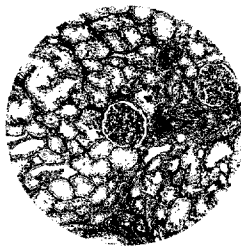

10x



20x



40x

Improper adjustment

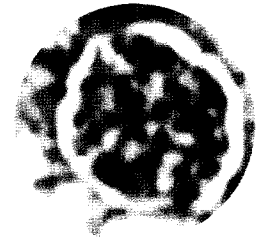
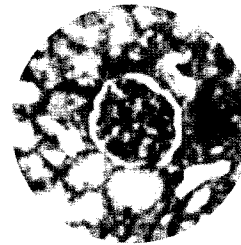
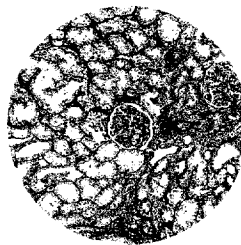
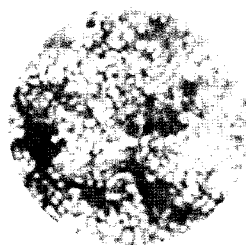

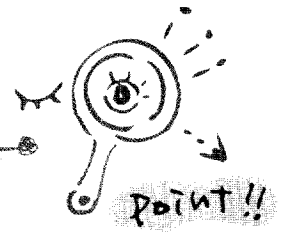

Effects of Condenser Focusing and Centering



Center the condenser so that the image of the field diaphragm appears clearly in the center of the view field. If not centered correctly, the center of the field diaphragm will be shifted out of position and resolution will be reduced. Always make these adjustments when assembling the microscope. → P.27

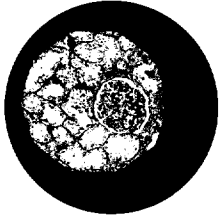

Off-center

Image of the field diaphragm is off-centered

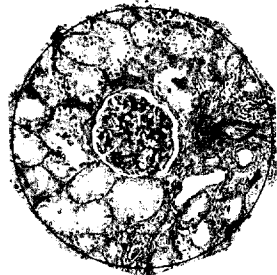

Correct adjustment

Image of the field diaphragm appears clearly in the center of the view field



Out of focus

Image of the field diaphragm appears fuzzy



Extremely out of focus

Extremely poor image quality

Effect of Color Balancing Filter (NCB11)



If specimens are observed with illumination from the lamp alone, their images are seen with a yellow tint. Using the NCB11 filter gives the images a natural color tone. This filter is normally used when observing specimens by bright field microscopy. → P.18



Using the NCB11 filter

Approximates natural daylight color



Without using the NCB11 filter

Yellowish color tone

Effect of Lamp Voltage Adjustment



If the lamp voltage is decreased, the color tone of the light becomes redder. Conversely, if the voltage is increased, the color tone of the light becomes bluer. Pressing the auto-photo switch and using the NCB11 filter results in the most natural color tone. → P.18



Low lamp voltage

Reddish color tone

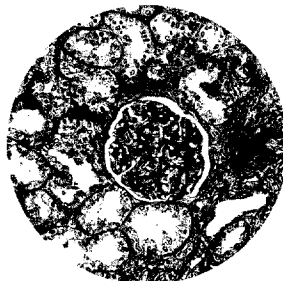

Auto-photo switch on

Approximates natural daylight color



High lamp voltage

Bluish color tone

Contents

Before Using	1-4
Names of Component Parts and Operational Parts	6-7
Proper Use Makes a Difference	10-11
Contents	13
Preparations for Microscopy	14
Placing a Specimen on the Stage	15
Changing Magnification	16
Photomicrography	17-18
Locking the Focus Position	19
Changing the Torque of the Coarse Focus Knob	20
Changing the Torque of the Stage Motion Control Knobs	20
Selecting a Condenser	21-22
Assembling and Disassembling the Microscope	23-25
Replacing the Lamp	26
Installing the Condenser	27
Installing the Stage	28
Installing the Objectives	28
Installing the Eyelevel Riser (If necessary)	29
Installing the Eyepiece Tube	29
Installing the Eyepieces	30
Lens Cleaning	30
Keeping the Microscope Clean	30
Storage	31
Regular Inspections	31
Troubleshooting Tables	32-34
Specifications and Ratings	35
Index	36



Preparations for Microscopy

- 1 Turn on the power switch. (Flip the switch to the " " side.) As soon as the power comes on, the switch lights.
- 2 Place the NCBI1 filter provided on the field lens and adjust the brightness adjuster to a suitable brightness.

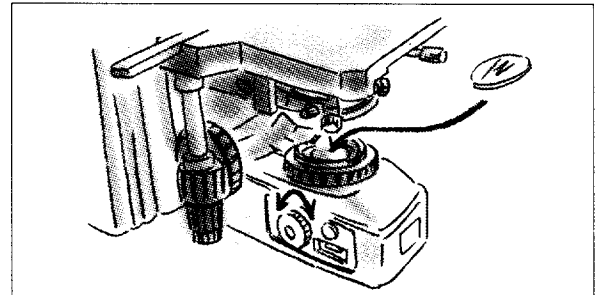

3 Diopter and Interpupillary Distance Adjustments

These adjustments are performed to adjust the microscope to the person using it. Continued use of the microscope without properly adjusting diopter and interpupillary distance can cause eye strain. Make sure to adjust the microscope properly whenever you use it. Diopter adjustment compensates for differences in vision between the left and right eyes. In addition to making observation through both eyes easier, this adjustment also reduces the defocusing when changing the objective. Perform diopter adjustment for both eyepieces, respectively.

- 3-1 Turn the diopter adjustment ring on the eyepiece to align the edge of the diopter adjustment ring with the engraved line. (This is the diopter adjustment "0" position.)

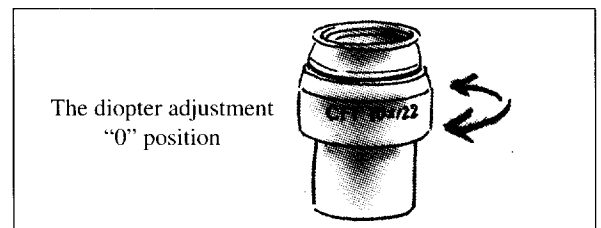

- 3-2 Turn the coarse and fine focus knobs to focus on the specimen with the 40× objective. (When it is difficult to focus on the specimen, first focus using the 4× or 10× objective, and then switch to the 40× objective.) Since the distance between the objective tip and the top of the cover glass is indicated as the working distance (WD) on the objective barrel, refer to that distance when focusing on the specimen.

- 3-3 Move the 4× or 10× objective into the optical path. Turn the diopter adjustment ring on the eyepiece, not the coarse and fine focus knobs, to focus on the specimen. Do so while peering through the right eyepiece with your right eye and the left eyepiece with your left eye.

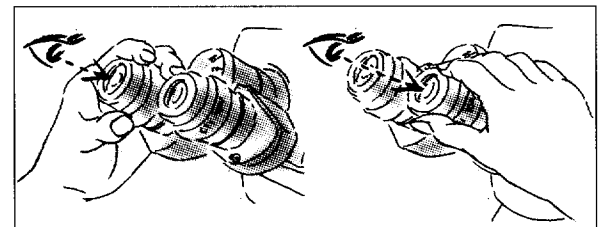

- 3-4 Adjust the spread of the binocular part to the distance between your eyes so that the field of view for each eye is aligned on one position when viewing with both eyes.

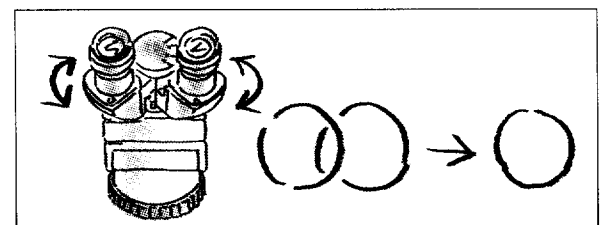

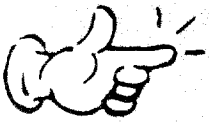

Placing a Specimen on the Stage

- 1 Place the slide glass containing the specimen on the stage with the cover glass facing up and pinch it in the specimen holder.

For one slide glass

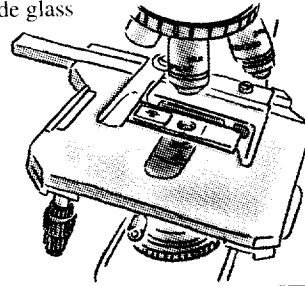

For two slide glasses

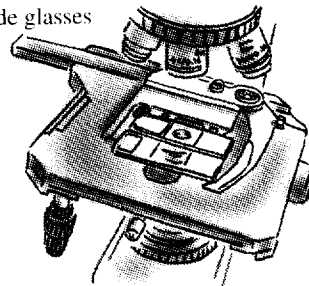

- 2 Adjust the illumination brightness with the brightness adjuster. Color of the light changes at the same time brightness changes. If brightness is reduced by lowering the voltage, the color tone of the light from the lamp becomes redder. If the voltage is increased, the color tone becomes bluer.
- 3 In order to maintain a constant color tone, adjust brightness by placing ND filter(s) on the NCB11 filter.

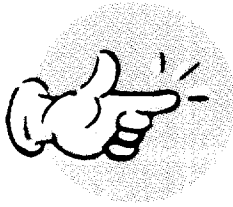

Changing Magnification

1 Adjustment of condenser aperture diaphragm

Adjust the diaphragm according to the objective numerical aperture. Turning the condenser aperture diaphragm ring changes the size of the aperture diaphragm. As the aperture diaphragm is stopped down, brightness reduces and the details of the specimen become more difficult to see, while contrast and depth of focus increase. Conversely, as the aperture diaphragm is opened, brightness increases and the details become easier to see, while contrast and depth of focus reduce. It is not possible to adjust one pair of characteristics without affecting the other. Generally, a well-defined image with appropriate contrast can be obtained with an aperture setting that is 70% to 80% of the objective numerical aperture. The numerical aperture of each objective is indicated on the barrel of the objective.

An indication of 40×/0.75 means that the magnification is 40× and the numerical aperture is 0.75.

If the aperture diaphragm is stopped down too far, specimen details will become difficult to see; therefore, except when contrast is extremely low such as when viewing a nearly transparent specimen, do not stop down the aperture to less than 60% of the numerical aperture of the objective.

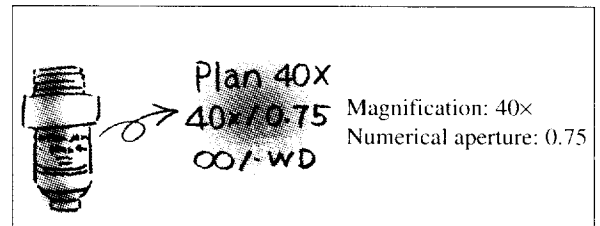

● Adjusting the size of the aperture diaphragm according to the condenser scale

Because the condenser scale indicates the numerical aperture, adjust the aperture diaphragm ring according to the scale.

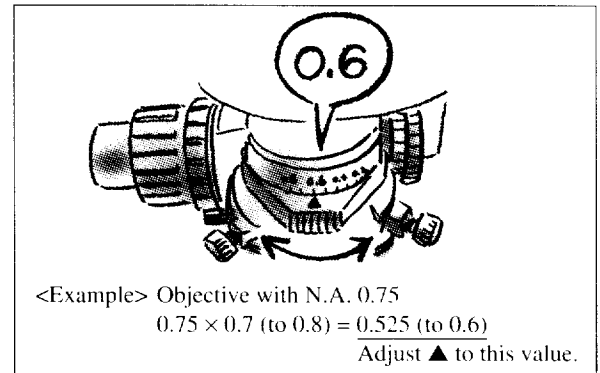

● Adjusting the size of the aperture diaphragm by using a centering telescope (sold separately)

Remove one of the eyepieces and, using a special adapter (sold separately), mount a centering telescope in its place. Turn the aperture diaphragm ring to stop down the aperture diaphragm as far as possible. While holding down the flange of the centering telescope, turn the eyepiece of the telescope to focus on the aperture diaphragm. Turn the aperture diaphragm ring to adjust the size of the aperture diaphragm. Remove the centering telescope and the adapter, and then reinstall the eyepiece.

2 Adjustment of field diaphragm

The field diaphragm limits illumination to the area of the specimen being viewed to prevent excessive light from entering the view field. Turning the field diaphragm ring changes the size of the field diaphragm. For normal observation, the size of the diaphragm should be just outside the edge of the view field. This adjustment can produce the image with appropriate contrast.

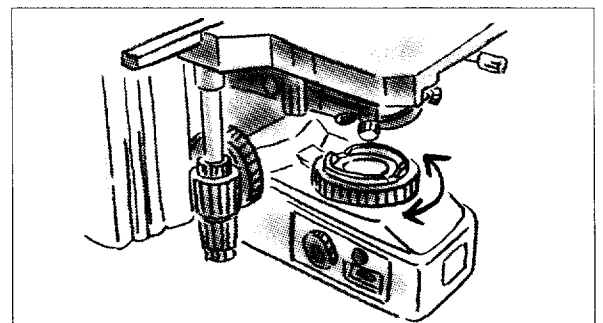



Photomicrography

- Refer to the instructions of the photomicrographic equipment being used for detailed information on the assembly method and photomicrographic procedure.

1 Selecting an eyepiece tube

A trinocular eyepiece tube equipped with a vertical tube is used. There are two types of trinocular eyepiece tubes. Select the tube according to the purpose of use.

Operating the optical path selection lever changes the amount of light entering the binocular part and vertical tube of the eyepiece tube as shown below.

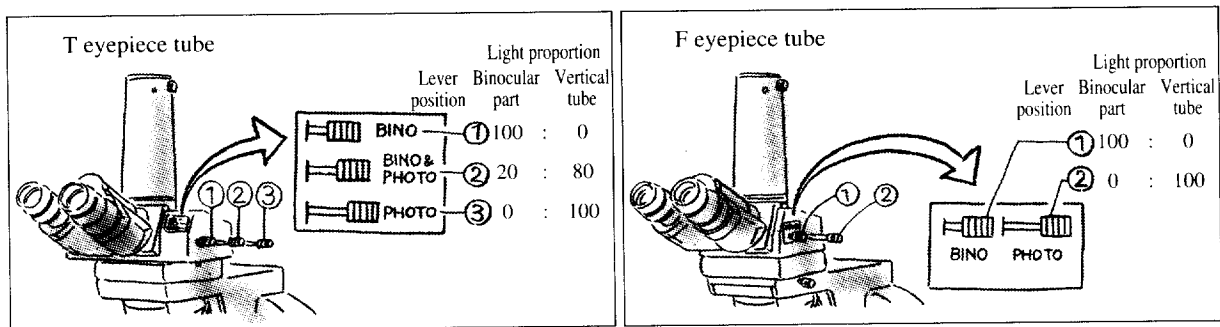

1-1 Vertical tube adapter

A photo vertical tube adapter is provided to the trinocular eyepiece tube as standard equipment. It allows a photomicrographic equipment to be installed. To install the photo vertical tube adapter, insert it into the vertical tube and tighten three clamp screws on the vertical tube using the hexagonal screwdriver provided. Replace the photo tube adapter with the TV vertical tube adapter (sold separately) in the case of using a TV camera.

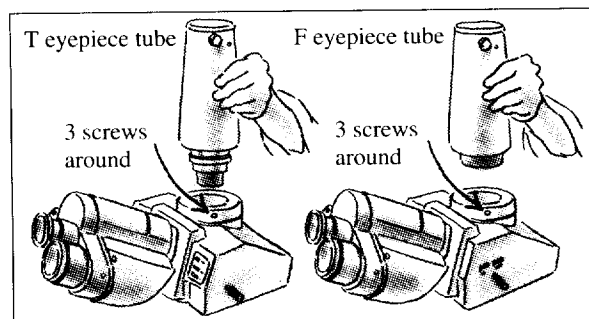

1-2 Release of T and F eyepiece tubes lever clicking

“NO CLICK” switch is used for minimizing slight vibrations produced by operation of the optical path selection lever. This switch is equipped on the bottom (installation) surface of the eyepiece tube. Turn the switch in the arrow direction using the hexagonal screwdriver provided, and the “NO CLICK” will become effective to remove the clicking action of the optical path selection lever.

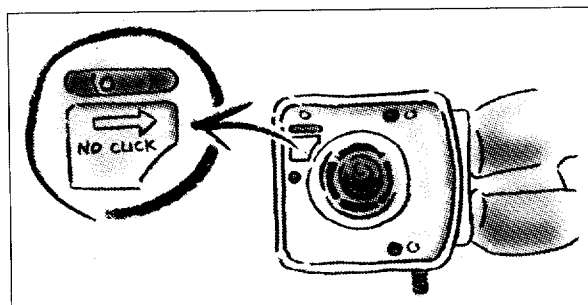



2 Selecting color tone and brightness

The color tone of the lamp varies according to the voltage. If the voltage is increased, the color tone of the lamp becomes bluer. If the voltage is decreased, the color tone of the lamp becomes redder. Therefore, in order to obtain the best color reproduction in color photomicrography, the lamp voltage should be kept constant. When using daylight-type color film, the standard setup is to use the color balancing filter (NCB11) and set the lamp voltage to the standard for photomicrography.

The auto-photo switch is used to automatically set the standard lamp voltage. If the image on color film shot with the auto-photo switch pushed are reddish or bluish, finely adjust the voltage with the auto-photo voltage selector switch. The center position of the 5-level slide switch is the standard position. Sliding the switch forward increases the bluish tint of the light, while sliding the switch towards the back increases the reddish tint of the light. If this adjustment is not enough to resolve the problem, also use commercially available color compensation filters (CC filters).

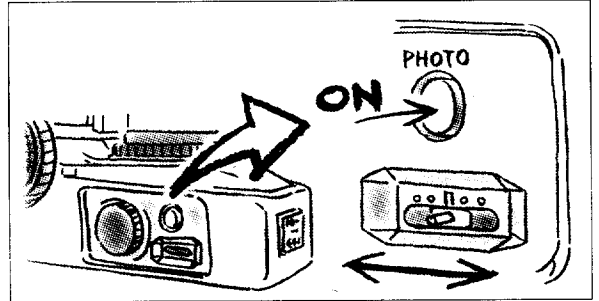

3 Trimming

Loosen the stage rotation clamp screw in order to rotate the stage. Tighten the clamp screw at the desired position and secure in position.

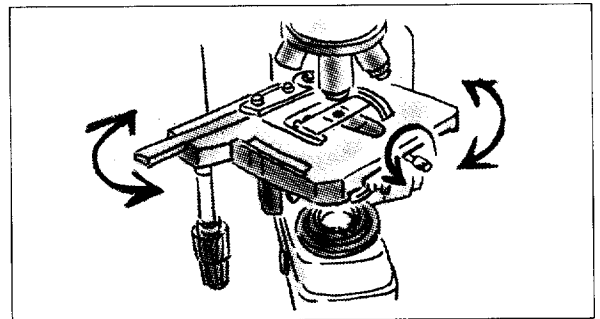



Locking the Focus Position

1 Coarse focus stopper

Once the coarse focus stopper is clamped in place, the coarse focus knob cannot be used to move the stage any higher. (Movement of the stage by the fine focus knob is not restricted.) In effect, once the coarse focus knob is clamped in place at the focus position, a rough focus can be attained the next time simply by turning the coarse focus knob as far as it will go.

This feature is convenient when viewing similar specimens one after another.

2 Using the coarse focus stopper

With the specimen in focus, turn the coarse focus stopper ring as far as it will go (about 270°) in the arrow direction indicated on the microscope base (i.e., clockwise direction). The coarse focus stopper is now clamped in place.

When changing the specimen, lower the stage by turning only the coarse focus knob.

After changing the specimen, gently raise the stage by turning only the coarse focus knob as far as it will go.

The specimen should be roughly in focus when the stage has been raised as far as it will go; use the fine focus knob to bring the specimen into perfect focus.

If the coarse focus stopper is not being used, be sure to loosen the coarse focus stopper ring as far as it will go (by turning it as far as it will go in the opposite direction of the arrow indicated on the microscope base).

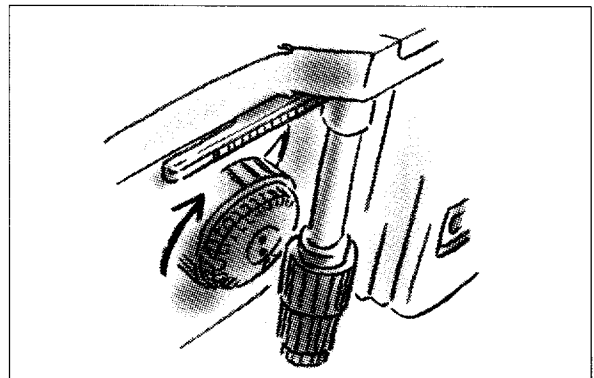

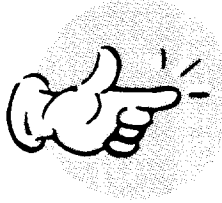

Changing the Torque of the Coarse Focus Knob

The torque of the coarse focus knob can be adjusted.

To increase the torque, turn the coarse torque adjustment ring (TORQUE) located behind the coarse focus knob in the arrow direction indicated on the microscope base (i.e., the counter-clockwise direction). To reduce the torque, turn the ring in the opposite direction of the arrow (i.e., clockwise direction).

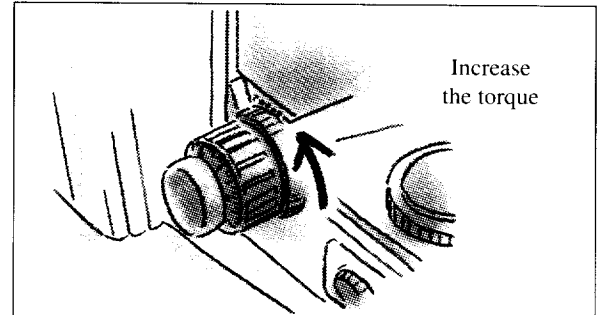

Never attempt either of the following actions. These actions will damage the microscope.

- Rotating the left and right knobs in opposite directions at the same time.
- Continuing to rotate the coarse focus knob after the stage has reached the limit of its motion.

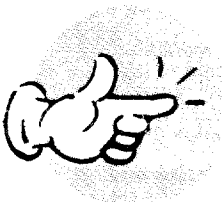
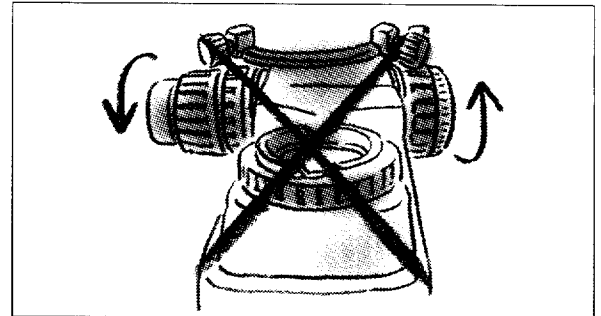

Changing the Torque of the Stage Motion Control Knobs

The torque of the X-axis and Y-axis stage motion control knobs can each be adjusted.

1 Adjustment of torque of Y-axis stage motion

To tighten the tension in the Y-axis, turn Knob B in the direction of arrow "a" while holding Knob A; to reduce the tension, turn Knob B in the opposite direction.

2 Adjustment of torque of X-axis stage motion

To tighten the tension in the X-axis, turn Knob C in the direction of arrow "b" while holding Knob D; to reduce the tension, turn Knob C in the opposite direction.

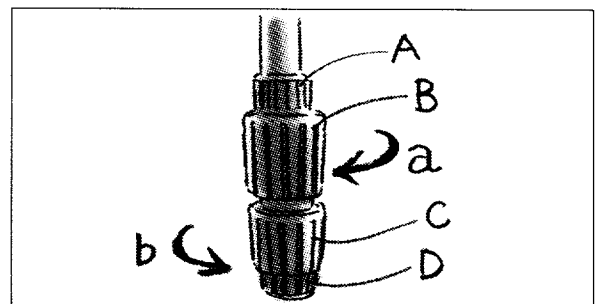



Selecting a Condenser

Objective magnification	Achromat/aplanat condenser	Swing-out condenser	Achromat condenser	Abbe condenser	Low-magnification condenser
1×	×	×	×	×	◎ (Note 2)
2×	×	(Note 3)	×	×	
4×	×		(Note 1)	(Note 1)	
10× to 100×	◎				×

◎: Optimum ○: Appropriate ×: Inappropriate

Note 1: The entire field of view may not be covered when a UW eyepiece is used.

Note 2: Indoor lighting and similar light sources may be reflected off the surface of the condenser lens and be visible within the field of view. When this happens, either dim the indoor lighting or prevent strong outside light from entering onto the stage.

Note 3: Swing out the top lens.

- Depending on the type of objective, the whole numerical aperture of the objective may not be covered. For example, when an objective with N.A. 1.4 is used in combination with a swing-out condenser or abbe condenser, the aperture size will only be about 65% of the objective's N.A. even when it is opened to its limit.
- For the universal system condenser and phase contrast condensers, refer to each instruction manual.

1 Oil-immersion operation (using an oil-immersion type objective and condenser)

Objectives marked "Oil" are oil-immersion type objectives. These objectives are used with the provided immersion oil applied between the specimen and the tip of the objective.

In order to get maximum performance from oil-immersion type objectives with a numerical aperture of 1.0 or greater, an oil-immersion type achromatic aplanat condenser must also be used. Oil-immersion type condensers are used with oil applied between the specimen and the condenser lens.

Bubbles in the oil will adversely affect the viewing of the image.

Be careful to prevent the formation of air bubbles. To check for air bubbles, remove the eyepieces, open the field diaphragm and the aperture diaphragm as far as possible, and look at the exit pupil of the objective within the eyepiece tube. (The exit pupil will appear as a bright circle.) If it is difficult to see if there are any bubbles, mount a centering telescope (sold separately) on an eyepiece sleeve by using an adapter (sold separately). Then, while turning the eyepiece on the centering telescope to change the focus, look through the centering telescope for air bubbles. If there are bubbles in the oil, remove them by one of the following methods:

- ◇ Turn the revolving nosepiece slightly to move the oil-immersed objective back and forth one or two times. (In the case of the condenser, gently turn the condenser focus knob to move the condenser up and down slightly.)
- ◇ Add more oil.
- ◇ Remove the oil and replace it with new oil.

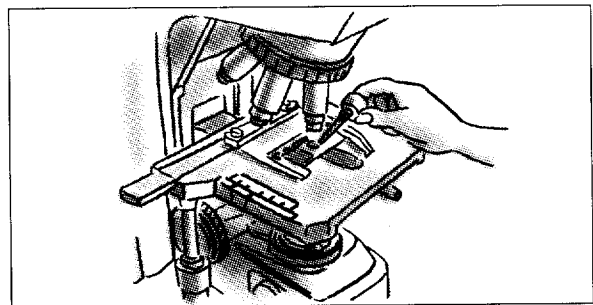

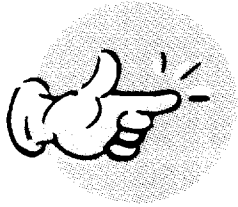

- Use as little oil as possible (just enough to fill the space between the tip of the objective and the specimen, or between the tip of the condenser and the specimen). If too much oil is applied, the excess will flow onto the stage and around the condenser.
- Any oil remaining on oil-immersion type objectives or on the tip of dry-type objectives has a negative effect on viewing. After using oil, wipe all of it away and make sure that there is no oil on the tips of the other objectives. The oil on the condenser lens should also be carefully wiped away after use.
- Use petroleum benzine to wipe away immersion oil. Finish the cleanup by wiping with absolute alcohol (ethyl alcohol or methyl alcohol).
- If you cannot obtain petroleum benzine, use methyl alcohol. But it will be necessary to wipe the surfaces repeatedly (usually, three or four times) to clean the lenses.



WARNING

- ◆ When using petroleum benzine or absolute alcohol, please follow the instructions provided by the manufacturer. Keep these flammable liquids away from fire or sparks.

Precautions when using immersion oil

- Make sure to securely tighten the cap after use. After adding oil to the container, securely tighten the base cap. Since the base cap may become loose by itself after having been used for a long time, periodically check to make sure it is tight. Oil may leak out if the cap is loose.
- Do not press on the container with excessive force. This may cause the oil suddenly spray from the container.
- Wipe off any oil that collects on the outside of the container during the course of use.
- Be careful so that oil does not get in your eyes. Although the oil is not toxic, apply the first-aid measures listed below if it should come in contact with the skin or enter the eyes.
 - ◇ Contact with skin: Completely wash off with soap and water.
 - ◇ Enters the eyes: Rinse thoroughly with pure water (for at least 15 minutes) and seek medical attention.
- Do not place immersion oil in a location exposed to outside light (or UV light).

2

Water-immersion operation (using a water-immersion type objective and condenser)

- Objectives marked “WI” or “W” are water-immersion type objectives. These objectives are used with the immersion water (distilled water or physiological saline) applied between the specimen and objective. Microscopy is performed in the same manner as for an oil-immersion type objective.
- Since water evaporates easily, periodically check it during observation. Applying excess water will cause it to flow onto the stage and condenser resulting in corrosion.
- After use, wipe any water from the tip of the objective and finish the cleanup process by wiping with absolute alcohol.
- When the water dries and leaves a stain, apply a small amount of neutral detergent and wipe gently to remove the stain. Finish the cleanup process by wiping with absolute alcohol.

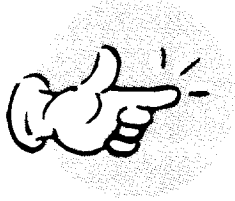

Assembling and Disassembling the Microscope



WARNING

- ◆ In order to prevent electrical shock and fire, turn off the power switch (flip to the “ ” side) during assembly.



CAUTION

- ◆ Attach the eyepiece tube first for assembling the microscope.
- ◆ When moving the microscope, securely grasp the arm from the back of the microscope with both hands.
- ◆ Do not grasp the coarse focus knob, the fine focus knob, eyepiece tube or stage, etc., when carrying the microscope; there is a chance that the part could come off, and the microscope could be damaged.
- ◆ Be careful not to bump the lamp cover on the back of the microscope when picking it up or putting it down.
- ◆ Be careful not to pinch your hands or fingers when setting up the microscope.
- ◆ Do not touch the lens surface with bare hands. Fingerprints or dirt on the lens will adversely affect the viewing of the image.
- ◆ This microscope is a precision optical device. Handle it carefully and do not subject it to strong physical shocks. (The precision of the objectives in particular may be adversely affected by even weak physical shocks.)

1

Tools needed

- Hexagonal screwdriver (1 provided)

When not using, insert it in the tool holder on the back of the microscope.

2

Confirm the input voltage

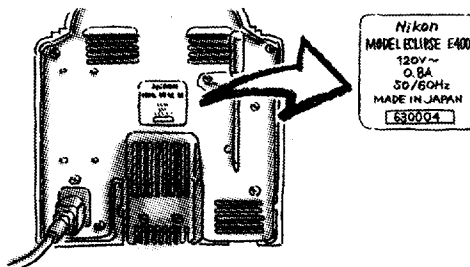

WARNING

- ◆ Make sure that the input voltage indicated on the back panel of the microscope is the same as your regional voltage.
- ◆ If the indicated voltage is different, do not use the microscope; instead, contact your nearest Nikon representative.
- ◆ If a microscope is used with the wrong input voltage, a short circuit or fire may result, and the microscope may be damaged.

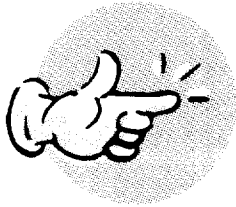

3 Connecting the power cord



WARNING

Use only the following power supply cord set.

◆ For 100-120V area

UL Listed, detachable cord set, 3 conductor grounding type SVT, No. 18 AWG rated at 125V, 7A minimum.

In case of using the extension cord, use only the power supply cord with the PE (protective earth) wire.

◆ For 220-240V area

3 pole power supply cord set, which must be approved according to EU/EN standards.

Class I equipment should be connected to PE (protective earth) terminal.

In case of using the extension cord, use only the power supply cord with the PE (protective earth) wire.

Turn off the microscope power switch by flipping it to the “ ” side before connecting the power cord.

After plugging the socket onto the AC input connector on the back of the microscope, securely insert the plug into an AC outlet.

4 Separately sold accessories installation

Install photomicrographic equipment and other separately sold accessories by referring to the instruction manual for each accessory.

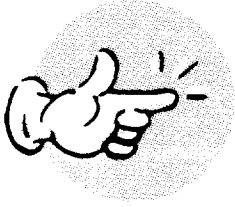

5 Microscope Component Units

- ECLIPSE E400 (revolving nosepiece and substage cannot be detached)
- Stage (specimen holder)
- Objectives (max. 5)
- Eyelevel riser
- Eyepiece tube (eyepieces)
- Condenser
- Lamp (lamp cover)
- Power cord

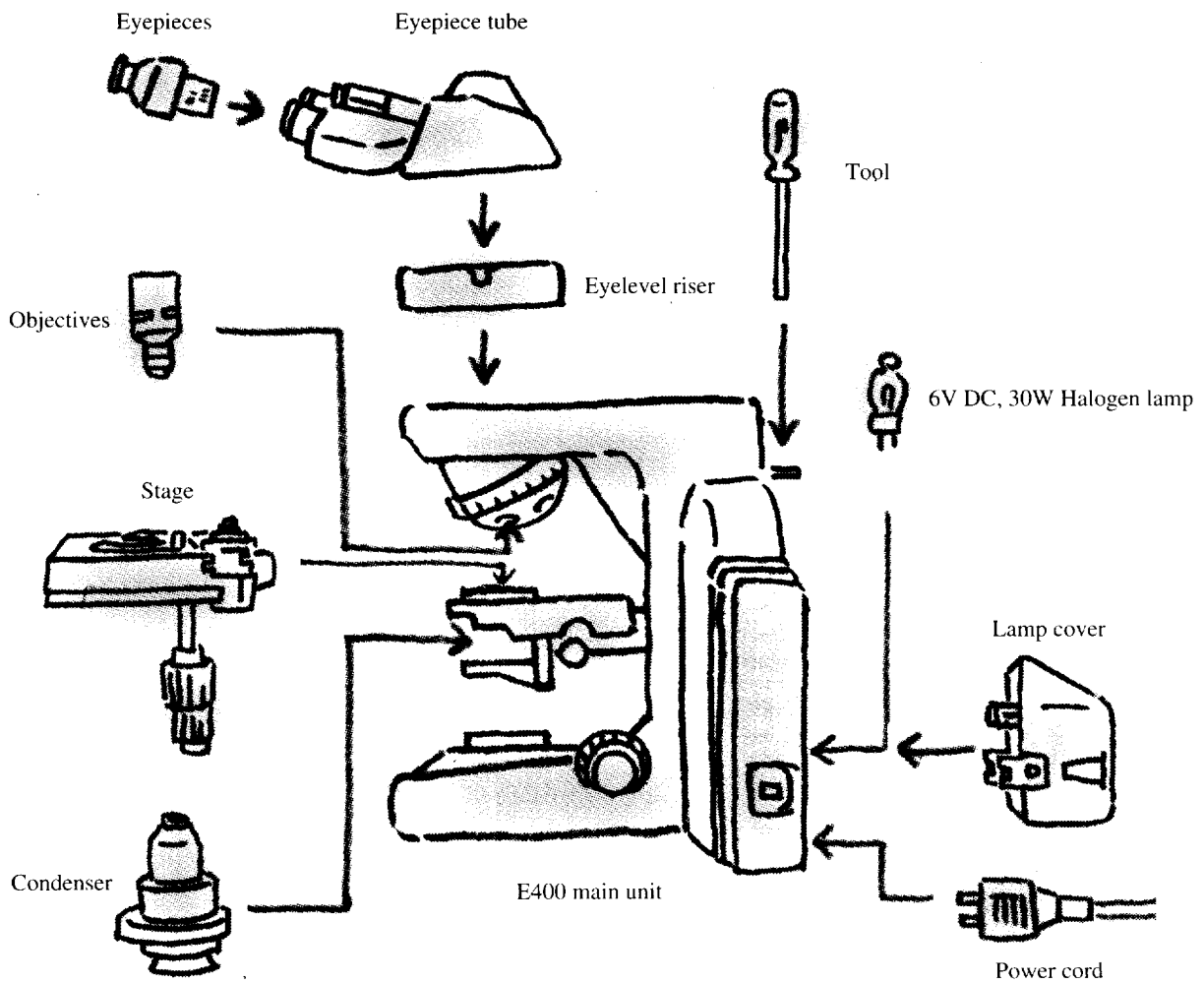



Replacing the Lamp

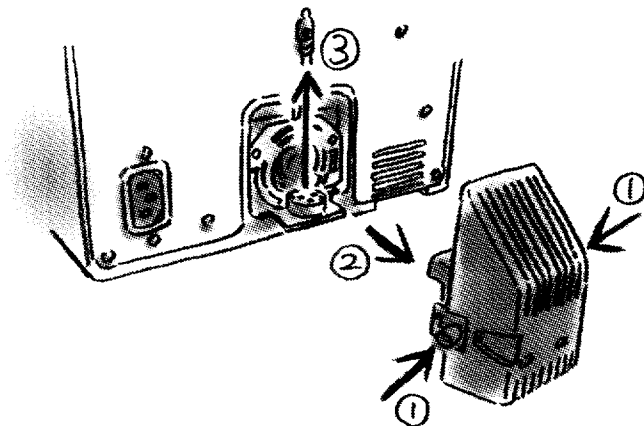

CAUTION

- ◆ In order to prevent electric shock and damage to the microscope, always turn off the power switch (flip it to the “ ” side) and unplug the power cord before replacing the lamp.
- ◆ In order to prevent burns, allow the lamp to cool before replacing it by waiting at least 30 minutes after using.
- ◆ Use a 6 V-30 W halogen lamp (PHILIPS 5761).
- ◆ Do not touch the glass portions of the lamp with your bare hands. Doing so will cause fingerprints, grease, etc., to burn onto the lamp surface, reducing the illumination provided by the lamp. If you do get any fingerprints or dirt on the lamp, wipe it clean.
- ◆ After replacing the lamp, make sure that the lamp cover is attached securely. Never use the lamp while its cover is off.



1 Confirm that the power switch is off (i.e., that it is flipped to the “ ” side).



2 Securely push the lamp into the socket pin holes as far as it will go. (Do not touch the glass portion of the lamp with your bare hands.)



3 Attach the lamp cover securely.

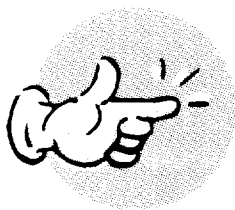

Installing the Condenser

1 Installation

- 1-1 Turn the condenser focus knob to lower the condenser holder as far as it will go.
- 1-2 Insert the condenser in the condenser holder.
- 1-3 Tighten the clamp screw on the left side with the aperture scale on the condenser facing to the front.
- 1-4 Turn the condenser focus knob to raise the condenser as far as it will go.

2 Focusing and centering

Focus and center the condenser so that the light passing through the condenser forms the image at the proper position on the specimen (i.e., at the center of the optical path).

- 2-1 Focus on the specimen with the 10× objective.
- 2-2 Close the field diaphragm to its minimum setting.
- 2-3 Turn the condenser focus knob so that the image of the field diaphragm forms on the specimen.
- 2-4 Adjust condenser centering screws so that the image of the field diaphragm appears roughly at the center of the eyepiece view field.
- 2-5 Move the 40× objective into the optical path. Turn the fine focus knob to focus on the specimen.
- 2-6 Turn the condenser focus knob so that the image of the field diaphragm forms on the specimen.
- 2-7 Adjust the condenser centering screws so that the image of the field diaphragm appears at the center of the eyepiece view field. This adjustment is easier to make if you adjust the size of the field diaphragm to slightly smaller than the eyepiece view field.



Installing the Stage

- 1 Sufficiently loosen the stage rotation clamp screw.
- 2 Place the stage on top of the substage and fit it in position so that it is level.
- 3 Tighten the rotation clamp screw with the stage facing to the front.

◆ **Note on removing/reinstalling specimen holder**

Release two clamp screws of the specimen holder with the stage dismantled from the substage. Securely clamp the screws when reinstalling the specimen holder.



Installing the Objectives

- 1 Lower the stage completely.
- 2 Screw the objectives into the revolving nosepiece so that the magnification increases when the revolving nosepiece is rotated in the clockwise direction when looking down on the revolving nosepiece from above.

◆ **Note on removing objectives**

If there is a specimen on the stage, remove it first.

Lower the stage completely, and hold each objective in both hands so that it does not fall when you remove it.

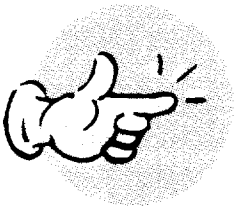

Installing the Eyelevel Riser (If necessary)

Eyelevel riser is used for adjusting the position of the eyepiece tube to the level of each operator's eyes when observing the microscope. It can be piled up to max. 4 pieces. 1 piece is provided as a standard. If you do not need the eyelevel riser, skip the procedure below.

- 1 Sufficiently loosen the eyelevel riser clamp screw on the microscope arm.
- 2 Insert the round dovetail on the eyelevel riser into the dovetail mount on the arm.
- 3 Tighten the eyelevel riser clamp screw to secure the eyelevel riser in place.

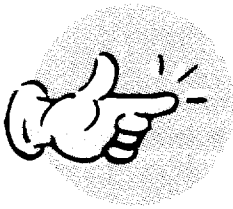

Installing the Eyepiece Tube

- 1 Sufficiently loosen the eyepiece tube clamp screw on the eyelevel riser using the hexagonal screwdriver provided.
- 2 Insert the round dovetail on the eyepiece tube into the dovetail mount on the eyelevel riser.
- 3 Tighten the eyepiece tube clamp screw with the screwdriver to secure the eyepiece tube in place.

◆ **When the eyelevel riser is not installed**

Insert the round dovetail on the eyepiece tube directly into the dovetail mount on the microscope arm, and tighten the eyelevel riser clamp screw on the arm.

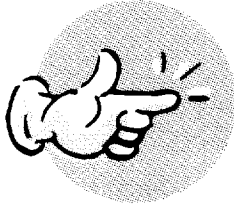

Installing the Eyepieces

- 1 Install the left and right eyepieces, both with the same magnification.
- 2 There are positioning protrusions on the right eyepiece sleeve. Align the notches of eyepiece with the protrusions on the sleeve and insert the eyepiece. (Some types of eyepiece tubes do not have protrusions on the sleeve.)
- 3 Put the rubber eyeguard (sold separately) onto the eyepiece by fitting to the groove around the eyepiece.

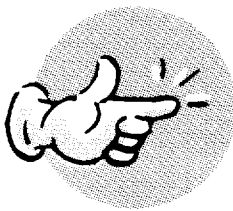

Lens Cleaning

- Brush away dust with a soft brush, or wipe it away gently with gauze.
- To clean fingerprints or grease on a lens, dampen a piece of soft, clean cotton cloth, lens tissue, or gauze with absolute alcohol (ethyl alcohol or methyl alcohol) and wipe.
- Use petroleum benzine to clean off immersion oil.
- Do not wipe the entrance lens on the eyepiece tube with petroleum benzine.
- Absolute alcohol and petroleum benzine are both highly flammable. Be careful when handling them. Avoid placing them near the lamp when it is hot and operating the power switch.
- Follow the instructions provided by the manufacturer when using absolute alcohol and petroleum benzine.

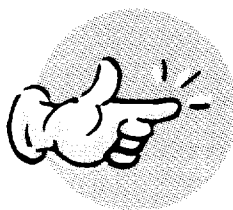

Keeping the Microscope Clean

Do not use organic solvents (such as alcohol, ether or paint thinner) on painted components, plastic components or printed components. Doing so could result in discoloration or in the peeling of printed characters. When the microscope is excessively dirty, soak up a small amount of diluted neutral detergent in a gauze and wipe gently.

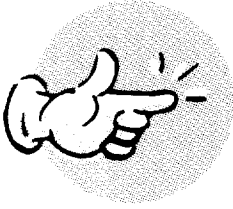

Storage

- Store the microscope in a place with low humidity and not subject to high temperatures. Storing in high-humidity locations can cause mold to form on the lenses.
- Store the objectives and eyepieces in a desiccator or similar container with a drying agent.
- Put the vinyl cover over the microscope to protect it from dust.
- Before putting on the vinyl cover, turn off the power switch on the microscope (flip the switch to the “O” side), and wait until the lamp is cool.

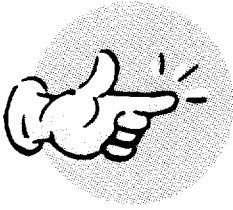

Regular Inspections

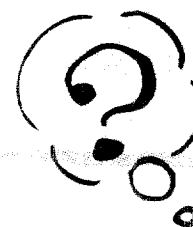

Regular inspections and maintenance of this microscope are recommended in order to maintain peak performance. Consult your nearest Nikon representative for details about regular inspections.

Troubleshooting Tables



Improper use of the microscope may adversely affect performance even if the microscope does not suffer damage. If any of the problems listed in the table below arise, take the countermeasures.



Viewing and control systems

 Problem	Cause	 Countermeasures
Vignetting of the view field; the entire view field cannot be seen; uneven brightness in the view field.	The optical path selector on the eyepiece tube is in an intermediate position.	Set the optical path selector 100% to the binocular eyepiece. (p.17)
	The optical path selector on the eyepiece tube is not set 100% to the binocular eyepiece.	
	The revolving nosepiece has not been rotated until it has clicked into place. (The objective is not in the optical path.)	Turn the revolving nosepiece until it clicks into place. (Place the objective in the optical path.)
	The condenser is too low.	Position the condenser so that the image of the field diaphragm forms properly on the specimen. (p.27)
	The condenser is not centered.	Center the condenser. (p.27)
	The condenser is not installed properly.	Install the condenser correctly. (p.27)
	The filters are not placed in proper position.	Correctly place on the field lens. (p.14)
	The field diaphragm is stopped down too far.	Open the diaphragm to a suitable size. (p.16)
	An unsuitable objective and condenser combination is being used.	Use a suitable combination. (p.21)
The lamp is not installed properly.	Install the lamp properly. (p.26)	
Dirt or dust in the view field	The condenser is too low.	Position the condenser so that the image of the field diaphragm forms properly on the specimen. (p.27)
	The aperture diaphragm is stopped down too far.	Open the diaphragm to a suitable size. (p.16)
	There is dirt or dust on the lens, condenser, eyepiece, filter or specimen.	Clean the components. (p.30)
Viewing is poor; details cannot be seen clearly; too much contrast; too little contrast.	The aperture diaphragm is stopped down too far.	Open the diaphragm to a suitable size. (p.16)
	The condenser is too low.	Position the condenser so that the image of the field diaphragm forms properly on the specimen. (p.27)
	The cover glass is too thick.	Use the specified type of cover glass (thickness: 0.17 mm).
	There is no cover glass.	
	There is no oil on the tip of an oil-immersion type objective.	Apply Nikon immersion oil. (p.21 and 22)
	The specified immersion oil is not being used.	
	There are bubbles in the immersion oil.	Remove the bubbles. (p.21)
There is immersion oil on the tip of a dry-type objective.	Clean the components. (p.30)	





Problem	Cause	Countermeasures
Viewing is poor; details cannot be seen clearly; too much contrast; too little contrast.	The compensation ring on an objective with a compensation ring has not been adjusted.	Adjust the compensation ring according to the cover glass.
	There is dirt or dust on the lens, condenser, objective or specimen.	Clean the components. (p.30)
Uneven focus	The revolving nosepiece has not been rotated until it has clicked into place.	Turn the revolving nosepiece until it clicks into place.
	The specimen is not secured in place on the stage.	Install the specimen properly on the specimen holder on the stage.
	The stage has been installed on a slant.	Install the stage correctly. (p.28)
Image flows	The revolving nosepiece has not been rotated until it has clicked into place.	Turn the revolving nosepiece until it clicks into place.
	The specimen is not secured in place on the stage.	Install the specimen properly on the specimen holder on the stage.
	The condenser is not centered.	Center the condenser. (p.27)
	The stage has been installed on a slant.	Install the stage correctly. (p.28)
Image is yellowish	An NCB11 filter is not being used.	Use the NCB11 filter. (p.14)
	The lamp voltage is too low.	
Image is too bright	The lamp voltage is too high.	Push auto-photo switch and then adjust the brightness through the ND filter combination. (p.15)
Inadequate illumination (also check the electrical system problems and countermeasures)	The lamp voltage is too low.	
	The aperture diaphragm is stopped down too far.	Open the diaphragm to a suitable size. (p.16)
	The condenser is too low.	Position the condenser so that the image of the field diaphragm forms properly on the specimen. (p.27)
Focusing is not possible with high-power objectives	The specimen is placed upside-down.	Affix the specimen on the stage with the cover glass facing up.
	The cover glass is too thick.	Use the specified type of cover glass (thickness: 0.17 mm).
The objective strikes the specimen when switching from a low-power objective to a high-power objective	The specimen is placed upside-down.	Affix the specimen on the stage with the cover glass facing up. (p.15)
	The cover glass is too thick.	Use the specified type of cover glass (thickness: 0.17 mm).
	The diopter adjustment has not been made.	Perform the diopter adjustment. (p.14)
The difference in focus when the objective is switched is large	The diopter adjustment has not been made.	Perform the diopter adjustment. (p.14)



 Problem	Cause	 Countermeasures
The specimen does not move smoothly	The specimen holder is not fixed securely in place on the stage.	Secure the specimen holder in place. (p.28)
When viewing through the binocular eyepiece, the image does not resolve into a single image	The interpupillary distance adjustment has not been made.	Perform the interpupillary distance adjustment. (p.14)
	The diopter adjustment has not been made.	Perform the diopter adjustment. (p.14)
Eye strain develops while viewing	The interpupillary distance adjustment has not been made.	Perform the interpupillary distance adjustment. (p.14)
	The diopter adjustment has not been made.	Perform the diopter adjustment. (p.14)
	The brightness level is not suitable.	Adjust the brightness through the ND filter combination. (p.15)

Electrical system

 Problem	Cause	 Countermeasures
The lamp does not light when the power switch is turned on	The power supply is not plugged in.	Plug the power cord into an outlet. (p.24)
	The power cord is not connected to the microscope.	Connect the power cord. (p.24)
	The lamp has not been installed.	Install the lamp. (p.26)
	The lamp is burned out.	Replace the lamp. (p.26)
	The specified lamp is not being used.	Use the specified lamp. (p.26)
The lamp flickers; the brightness is unstable	The lamp is near the end of its life.	Replace the lamp. (p.26)
	The power cord is not connected securely.	Secure the connection. (p.24)
	The lamp is not plugged into its socket securely.	Insert the lamp securely into its socket. (p.26)

Specifications and Ratings

1 | Model Name: ECLIPSE E400 (microscope main body)

2 | Focusing Mechanism

- Fine focus knob scale: 1 step equals 1 μm
- Amount of movement of fine focus knob: One turn moves the stage up or down by 0.1 mm
- Amount of movement of coarse focus knob: One turn moves the stage up or down by about 12 mm
- Range of stage vertical motion: 2 mm up and 28 mm down from the reference (focused) position

3 | Stage

- Provided with a knob torque adjustment mechanism
- Provided with a rotation mechanism

4 | Revolving Nosepiece

- Locking type with five-holes

5 | Illumination

- Internal Koehler-type diascope illumination optics
- Provided with a PHOTO switch (5-level fine adjustment selector)
- Lamp rating: 6 V DC, 30 W halogen lamp, PHILIPS 5761

6 | Input Power Supply Voltage

- AC 100V/120V $\pm 10\%$ 50/60Hz
 - Current consumption: 0.8A or less
 - Internal fuse rating: 250V, T2A
- AC 230V $\pm 10\%$ 50/60Hz
 - Current consumption: 0.4A or less
 - Internal fuse rating: 250V, T2A

7 | Protection Class

- Class I

8 | Operating Environment

- Temperature: 0 to +40°C
- Humidity: Relative humidity max. 85%, non-condensing
- Altitude: Max. 2000 m
- Pollution: Degree 2
- Installation: Category II
- Indoor use only

9 | Conforming Standards

- Product with AC 120 V:
 - UL Listed product
 - FCC 15B Class A satisfied

This equipment has been tested and found to comply with the limits for a Class A digital device pursuant to Part 15 of the FCC Rules. These limits are designed to provide reasonable protections against harmful interference when the equipment is operated in a commercial environment. This equipment generates, uses, and can radiate radio frequency energy and if not installed and used in accordance with the instruction manual, may cause harmful interference to radio communications. Operation of this equipment in a residential area is likely to cause harmful interference in which the user will be required to correct the interference at this own expense.

This Class A digital apparatus meets all requirements of the Canadian Interference-Causing Equipment Regulations.
Cet appareil numérique de la Classe A respecte toutes les exigences du Règlement sur le matériel brouilleur du Canada.

- Product with AC 230 V:
 - GS approved product
 - EU Low Voltage Directive satisfied
 - EU EMC Directive satisfied

Index

● Absolute alcohol	22, 30
● Aperture diaphragm	10, 16
● Aperture diaphragm ring	16
● Auto-photo switch	11, 18
● Centering telescope	16
● Coarse and fine focus knobs	14
● Coarse focus stopper	19
● Color balancing filter (NCB11)	11, 18
● Color compensation (CC) filter	18
● Color film	18
● Color tone	11, 18
● Condenser focusing and centering	11, 27
● Contrast	10, 16
● Diopter adjustment	10, 14
● Diopter adjustment ring	14
● Eyelevel riser	29
● Field diaphragm	16
● Input voltage	2, 23
● Installation location	3
● Interpupillary distance adjustment	14
● Lamp voltage	11, 18
● Numerical aperture	10, 16
● Oil-immersion	21
● Petroleum benzine	22, 30
● Photo vertical tube adapter	17
● Power cord	2, 24
● Power switch	14
● Release of T and F eyepiece tubes lever clicking	17
● Round dovetail	29
● Specified lamp	3, 26
● Specimen holder	28
● Substage	28
● Torque adjustment	20
● Trinocular eyepiece tube	17
● Trimming	18
● TV vertical tube adapter	17
● Water-immersion	22
● Wiping off oil	22, 30